

Instruction Manual

COND METER DS-72

■ Preface

This manual describes the operation of the DS-72 COND Meter.

Be sure to read this manual before using the product to ensure proper and safe operation of the instrument. Also safely store the manual so it is readily possible whenever necessary.

Product specifications and appearance, as well as the contents of this manual are subject to change without notice.

■ Warranty and Responsibility

HORIBA, Ltd. warrants that the Product shall be free from defects in material and workmanship and agrees to repair or replace free of charge, at option of HORIBA, Ltd., any malfunctioned or damaged Product attributable to responsibility of HORIBA, Ltd. for a period of one (1) year from the delivery unless otherwise agreed with a written agreement. In any one of the following cases, none of the warranties set forth herein shall be extended;

- Any malfunction or damage attributable to improper operation
- Any malfunction attributable to repair or modification by any person not authorized by HORIBA, Ltd.
- Any malfunction or damage attributable to the use in an environment not specified in this manual
- Any malfunction or damage attributable to violation of the instructions in this manual or operations in the manner not specified in this manual
- Any malfunction or damage attributable to any cause or causes beyond the reasonable control of HORIBA, Ltd. such as natural disasters
- Any deterioration in appearance attributable to corrosion, rust, and so on
- Replacement of consumables

HORIBA, LTD. SHALL NOT BE LIABLE FOR ANY DAMAGES RESULTING FROM ANY MALFUNCTIONS OF THE PRODUCT, ANY ERASURE OF DATA, OR ANY OTHER USES OF THE PRODUCT.

■ Trademarks

Generally, company names and brand names are either registered trademarks or trademarks of the respective companies.

■ Unauthorized Reprinting or Copying of This Operation Manual

No unauthorized reprinting or copying of all or part of this operation manual is allowed. The utmost care has been used in the preparation of this operation manual.

REGULATIONS

■ Conformable Directive

This equipment conforms to the following directives and standards:



Directives: The EMC Directive 2004/108/EC
The Low Voltage Directive 2006/95/EC

Standards: [the EMC Directive] EN61326-1:2006
Class B, Basic requirements
[the Low Voltage Directive] EN61010-1:2010(Ed.3.0)

● Installation Environment

This product is designed for the following environment.

- Overvoltage category II
- Measurement category I

WARNING: Do not use the equipment for measurements within measurement categories II, III and IV.

● Information on Disposal of Electrical and Electronic Equipment and Disposal of Batteries and Accumulators

The crossed out wheeled bin symbol with underbar shown on the product or accompanying documents indicates the product requires appropriate treatment, collection and recycle for waste electrical and electronic equipment (WEEE) under the Directive 2002/96/EC, and/or waste batteries and accumulators under the Directive 2006/66/EC in the European Union.

The symbol might be put with one of the chemical symbols below. In this case, it satisfies the requirements of the Directive 2006/66/EC for the object chemical.

This product should not be disposed of as unsorted household waste. Your correct disposal of WEEE, waste batteries and accumulators will contribute to reducing wasteful consumption of natural resources, and protecting human health and the environment from potential negative effects caused by hazardous substance in products.

Contact your supplier for information on applicable disposal methods.

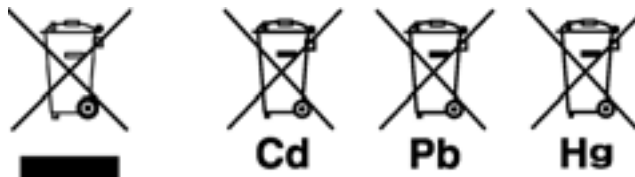

REGULATIONS

■ FCC Rules

Any changes or modifications not expressly approved by the party responsible for compliance shall void the user's authority to operate the equipment.

● WARNING

This equipment has been tested and found to comply with the limits for a Class A digital device, pursuant to part 15 of the FCC Rules. These limits are designed to provide reasonable protection against harmful interference when the equipment is operated in a commercial environment. This equipment generates, uses, and can radiate radio frequency energy and, if not installed and used in accordance with the instruction manual, may cause harmful interference to radio communications.

Operation of this equipment in a residential area is likely to cause harmful interference in which case the user will be required to correct the interference at his own expense.

■ Hazard Classification and Warning Symbols

Warning messages are described in the following manner. Read the messages and follow the instructions carefully.

● Hazard classification



This indicates an imminently hazardous situation which, if not avoided, will result in death or serious injury. This signal word is to be limited to the most extreme situations.



This indicates a potentially hazardous situation which, if not avoided, could result in death or serious injury.



This indicates a potentially hazardous situation which, if not avoided, may result in minor or moderate injury. It may also be used to alert against unsafe practices. Without safety alert indication of hazardous situation which, if not avoided, could result in property damage.

● Warning symbols



Description of what should be done, or what should be followed



Description of what should never be done, or what is prohibited

SAFETY OPERATION

■ Safety Precautions

This section provides precautions to enable you to use the product safely and correctly and to prevent injury and damage. The terms of DANGER, WARNING, and CAUTION indicate the degree of imminency and hazardous situation. Read the precautions carefully as it contains important safety messages.



WARNING



Do not use an unspecified AC adapter.
Otherwise, it may heat up or be ignited resulting in a fire or an accident.



Do not disassemble or modify the meter.
Otherwise, it may heat up or be ignited resulting in a fire or an accident.



CAUTION



Broken glass

Broken glass may cause injury.
The outer tube and tip of an electrode are made of glass.
Handle them with care.



Do not use the cable of serial communication, USB, or AC adapter under wet or humid conditions.
Otherwise, it may cause a fire, electric shock, or breakage.

■ Product Handling Information

● Operational Precautions

- Do not drop, crash, or give any physical impact on the instrument.
- Do not immerse the instrument into alcohol, organic solvent, strong acid, strong alkaline, or the like. The instrument body contains ABS resin, acrylic resin, and some rubber parts.
- If the instrument is dropped into water or gets wet, wipe it using soft cloth. Do not heat to dry it with a hair-dryer (or the like).
- Use fingers to press the operation keys or the touch panel. Do not use a hard object like a metal stick or rod.
- Be careful not to let water into the instruction inside. The instrument is not water-proof.
- To disconnect an electrode or interface cable, hold the connector and pull it off. If you pull at the cable, it may cause a breakage.
- The touch panel is capacitance-type. Make sure to turn OFF the power before cleaning the panel. If you wipe it with the power ON, it may cause instrument malfunction.
- RS-232C or USB communication between the instrument and a personal computer may fail because of environmental conditions, such as (radio/electromagnetic) noise.

● Environmental conditions for use and storage

- Temperature: 0°C to 45°C
- Humidity: under 80% in relative humidity and free from condensation

Avoid the following conditions:

- Dusty environment
- Strong vibration
- Direct sunlight
- Corrosive gas environment
- Close to an air-conditioner
- Direct wind

● Transportation

When transporting the instrument, repackage it in the original package box. Otherwise, it may cause instrument breakage.

● Disposal

Standard solution used for the calibration must be under neutralized before the disposal. As for the disposal of the meter, treat it as an industrial waste.

■ Description in This Manual

— **NOTE** —

This interprets the necessary points for correct operation and notifies the important points for handling the instrument.

— **REF** —

This indicates the part of where to refer the information.

— **HINT!** —

This indicates reference information.

Contents

Chapter 1 OVERVIEW	1
1.1 Description of Each Part	1
1.1.1 Rear	1
1.1.2 Display	1
1.1.3 Left Side	2
1.1.4 Right Side	2
1.1.5 Accessories	2
1.1.6 Operation Keys	3
1.1.7 Icons (Icon Bar)	4
1.1.8 Status Icons	5
1.1.9 Meas Screen	6
1.2 Basic Operation of Touch-Panel and Touch-Key	7
1.3 Function and Operation of the Meas Screen	8
1.4 Assembling the Electrode Stand	10
1.5 Connecting the Electrode	11
1.5.1 Electrode Connector	11
1.5.2 Temperature Connector	11
1.6 Connecting the Power Source	12
1.7 Connecting the Printer	12
1.8 Connecting the Personal Computer	13
1.9 Turn ON the Power	14
Chapter 2 Before Measurement (Meter SET)	15
2.1 Meter SET Screen	15
2.2 Auto Hold Setting	15
2.3 Custom Setting	16
2.4 Sample Name Setting	17
2.5 Interval Memory Setting	18
2.6 USB Memory Setting	19
2.7 Printer Setting	21
2.8 Screen Settings	23
2.9 Sound Setting	25
2.10 Language Setting	26
2.11 Security Setting	26
2.12 User Entry/Info Change/Delete	28
2.13 Date Setting	30
2.14 Analog Output Adjustment	31
2.15 Temperature Sensor Calibration	32
2.16 Resetting to Factory Defaults	33
Chapter 3 COND (conductivity) Measurement	34
3.1 COND Calibration Setting	34
3.1.1 Cell Constant Setting	34
3.1.2 Calibration of Standard Solution	35
3.2 COND Measurement Setting	36

Contents

3.3 COND Measurement Unit Setting	36
3.4 Temperature Setting	37
3.4.1 Solution Temperature Entry in MTC (Manual Temperature Compensation)	37
3.5 Temperature Conversion Function Setting	38
3.5.1 Input Temperature Conversion Factor	38
3.6 Alarm Setting	39
3.6.1 Input Upper or Lower Limit Values	39
3.7 Electrode Model Setting	41
3.7.1 Electrode Model Selection	41
3.7.2 Electrode Model Entry	41
3.8 Electrode Lot No. Setting	42
3.9 COND Measurement	43
Chapter 4 SAL (Salinity) Measurement	44
4.1 SAL Calibration Setting	44
4.2 SAL Measurement Setting	45
4.3 SAL Measurement Unit Setting	45
4.4 Temperature Setting	45
4.5 Alarm Setting	46
4.5.1 Input Upper or Lower Limit Values	46
4.6 Electrode Model Setting	47
4.7 SAL Measurement	47
Chapter 5 Resist (Resistivity) Measurement	48
5.1 Resist Measurement Setting	48
5.2 Resist Measurement Unit Setting	48
5.3 Temperature Setting	48
5.4 Alarm Setting	49
5.4.1 Input Upper or Lower Limit Values	49
5.5 Electrode Model Setting	50
5.6 Resist Measurement	50
Chapter 6 TDS (Total Dissolved Solids) Measurement	51
6.1 TDS Measurement Setting	51
6.2 TDS Measurement Mode Setting	51
6.2.1 Input TDS Factor Value when Select FACTOR	51
6.3 Temperature Setting	52
6.4 Alarm Setting	52
6.4.1 Input Upper or Lower Limit Values	52
6.5 Electrode Model Setting	53
6.6 TDS Measurement	53
Chapter 7 Application Mode	54

Contents

7.1 Pharmacopeia Mode	54
7.1.1 Shift to Pharmacopeia Mode	55
7.1.2 Measured by USP (Stage 1)	55
7.1.3 Measured by USP (Stage 2)	56
7.1.4 Measured by EP	57
7.1.5 Measured by JP (OFF-LINE)	58
7.1.6 Measured by JP (0mL-10mL (in container))	59
7.1.7 Measured by JP (10mL- (in container))	60
7.1.8 Measured by PPRC (CP) (Stage 1)	61
7.1.9 Measured by PPRC (CP) (Stage 2)	62
7.1.10 Temperature and Conductivity Requirements	63
Chapter 8 Periodic Inspection Mode	64
8.1 COND Periodic Inspection Mode Setting	64
8.1.1 Pharmacopoeia Mode	64
8.1.2 COND Checker (X-52) Mode	66
8.2 Comment Input	67
Chapter 9 Data	68
9.1 Measurement data_All	68
9.2 Deleting Saved Data	68
9.3 Measurement data_latest50	69
9.4 Measured data_Search	69
9.5 Copy all Meas. Data	70
9.6 Delete all meas. Data	70
Chapter 10 Specifications	71
10.1 Specifications	71
10.2 Default Settings	72
10.2.1 Meter Default Settings	72
10.2.2 Measurement Condition Default Settings (Can be set per operator)	73
10.3 Options	75

Chapter 1 OVERVIEW

This chapter describes functions and basic operations of the instrument.

1.1 Description of Each Part

1.1.1 Rear

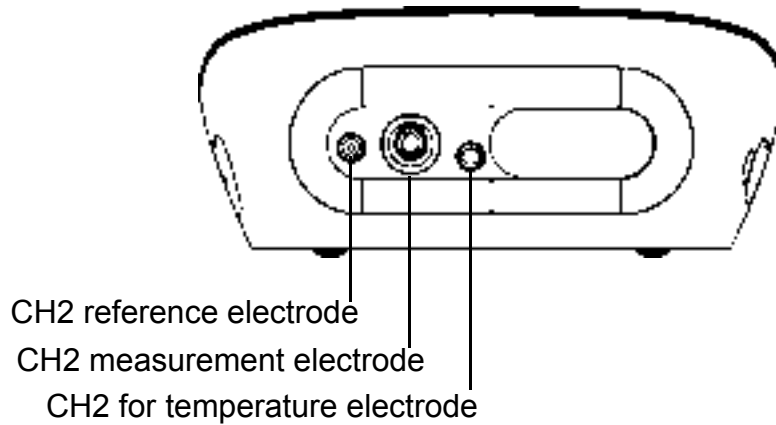

1.1.2 Display

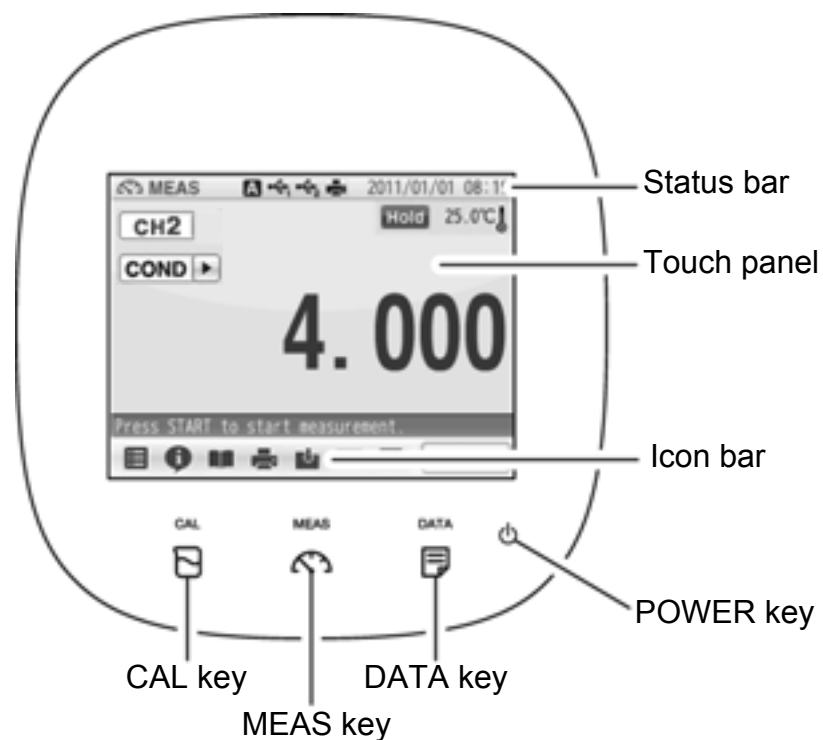

Chapter 1 OVERVIEW

1.1.3 Left Side

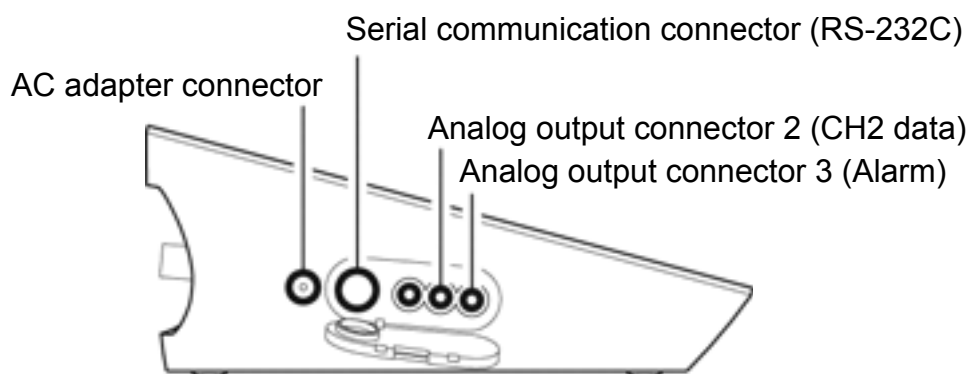

1.1.4 Right Side

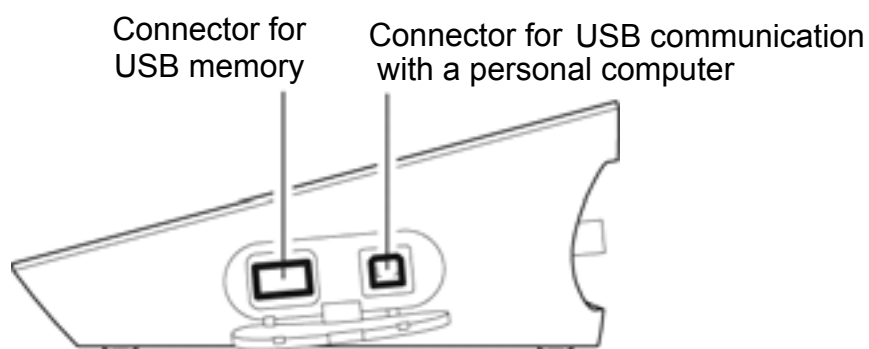







1.1.5 Accessories

Name	Function
AC adapter	Used to power the instrument.
Electrode stand	Used to move and set electrodes during measurement.
Rubber cover	Protects the instrument side surfaces.
Instruction manual	Instructs the usage of the instrument.
Quick manual	Instructs the operations of calibration and measurement.
Ferrite core	Attach this device to the AC adapter cable to reduce interference.

*Clock battery (CR-2032) is put into the battery cover at the instrument bottom.

1.1.6 Operation Keys



Operation key		Function
	POWER	Turns ON or OFF the power. (Press and hold for 2 seconds or more.)
 	CAL	Displays the calibration screen (CAL screen).
 	MEAS	Displays the measurement screen (MEAS screen).
 	DATA	Displays the data screen (DATA screen).

NOTE

The POWER key does not work for 10 seconds after the AC adapter is connected. Wait for a while after connecting AC adapter.

1.1.7 Icons (Icon Bar)

The icons displayed on the bottom of the touch panel allow you to set up the instrument, check calibration information, and print out and save data.







Icon		Function
	Menu	Used to perform measurement, display the Meter SET screen, and switch to the inspection and application modes.
	Information	Used to check calibration information on the MEAS or CAL screen, and application information on the Meter SET screen.
	User's guide	Used to check operation instructions and information about measurement and maintenance.
	Printer	Used to print out measurement or calibration values or saved data when a printer is connected.
	Save in USB	Used to save measured data into a USB memory.
	Save data	Used to save measurement values displayed on the screen into the instrument.
	Trash box	Used to delete calibration data or the data saved in the instrument.
	Operation	Used to start and stop the operations of measurement and calibration, and to change to the instantaneous value display. The icon label depends on the corresponding operation.

1.1.8 Status Icons

The icons displayed on the top of the touch panel show information on the instrument.





Status icon		Function
	Auto hold	Shows that the automatic hold function is ON, and that the end point is determined automatically according to input signals from the electrode based on the pre-selected stability criterion of measurement values. Refer to "2.2 Auto Hold Setting" (P.15).
	Manual hold	Shows that the manual hold function is ON, and that the end point is determined manually. Refer to "2.2 Auto Hold Setting" (P.15).
	USB1 ^{*1}	Shows that the instrument is connected with a personal computer via a USB cable.
	USB2 ^{*1}	Shows that the instrument is connected with a USB data storage media.
	Printer	Shows that the instrument is connected with a printer with a dedicated printer cable.

*1: These icons appear when a USB cable is connected, but it does not always mean that the communication is conducted.

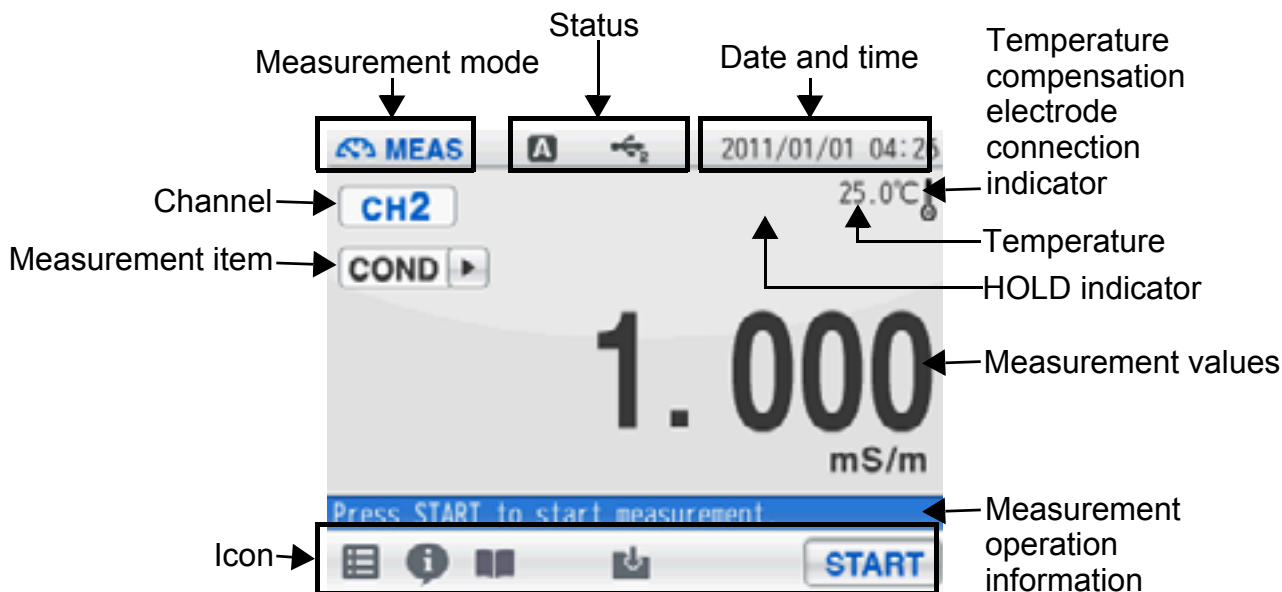
1.1.9 Meas Screen





Indicator	Name	Description
	Temperature compensation electrode connection indicator	Displayed: A temperature compensation electrode is connected. The displayed temperature is the electrode temperature (ATC). Not displayed: The displayed temperature is preset value (MTC).
	HOLD indicator	Not displayed: An instantaneous value is displayed. Blinking: In-process for HOLD Lighting up: HOLD completed.

1.2 Basic Operation of Touch-Panel and Touch-Key

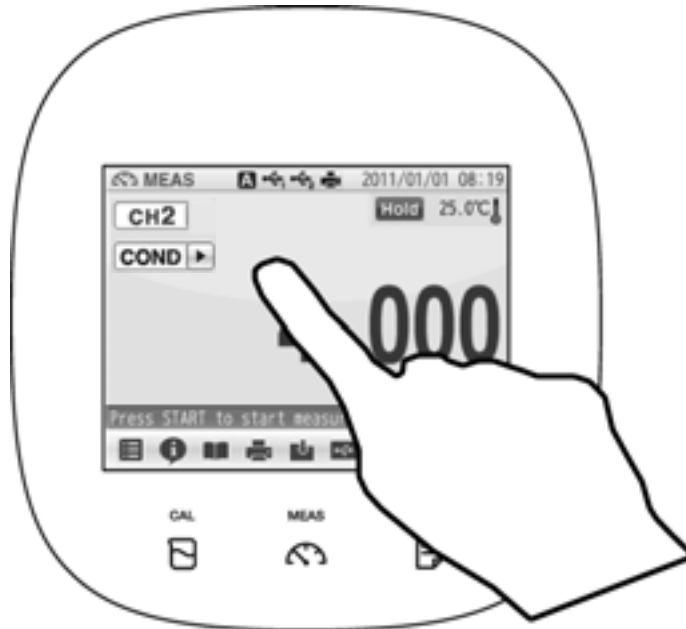
The instrument has touch panel and keys and you can operate it by touching the screen. The 3 basic operations of Tap, Flick, and Drag allow you to operate the instrument intuitively. This section describes the basic operations.



Operation	Description
Tap 	Tap on the screen lightly once with a finger. Tap a menu item or icon to select it or change settings.
Flick 	Touch and flick on the screen with a finger. Used to switch to the digital or graph display on the MEAS or CAL screen.
Drag 	Keep a finger in contact with the screen and drag it on the screen. Used to search a setting item, or measurement data on the DATA screen. When a scroll bar is displayed on the right of the screen, you can scroll the screen by this operation.



1.3 Function and Operation of the Meas Screen

The MEAS screen has three display methods to check variation and tendency of measurement values.

You can shift the screen to the digital, graph or analog screen by flicking it.

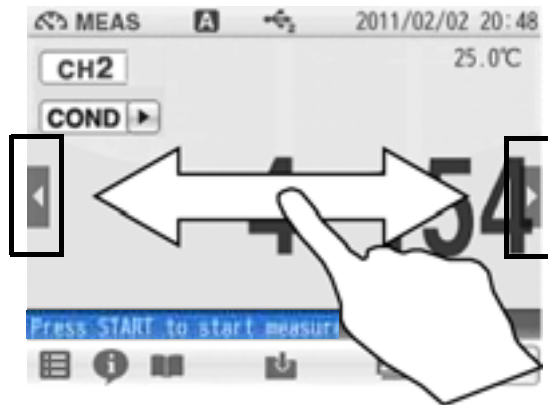
Digital display



If arrows, like  and , appear when you touch the screen, you can flick in the directions to switch the screen display.

Graph display

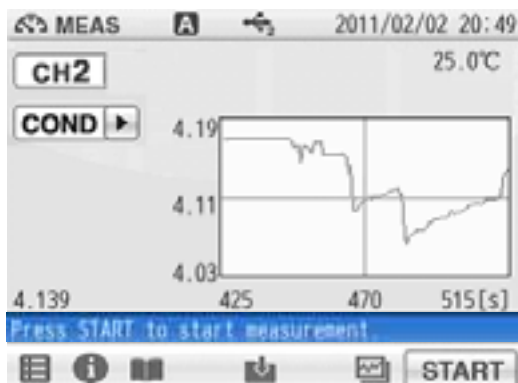

Analog display

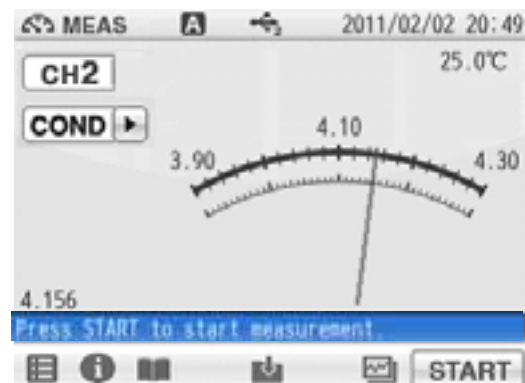

● **Graph display**

You can change the scale of the vertical axis in the graph display. It allows you to check a small change in measurement values.

The vertical axis is zoomed in. The displayed range narrows.

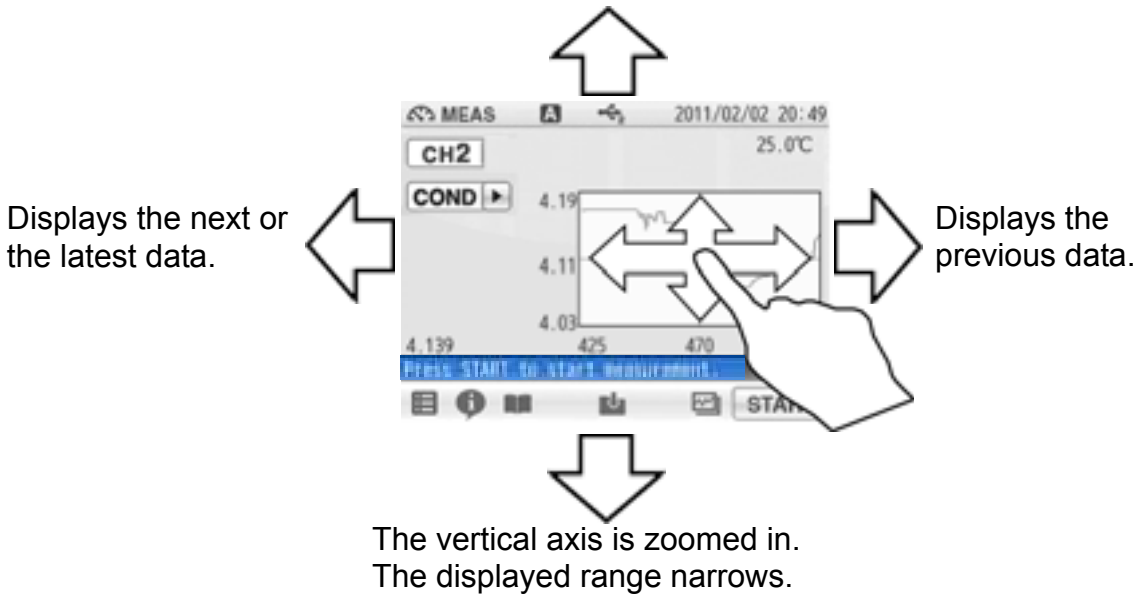

Tap on the screen after the above operations, and the latest data will be displayed in optimized range.

● **Analog display**

You can change the scale of the vertical axis in the analog display. It allows you to check a small change in measurement values.

The displayed range narrows. It allows you to check the detailed variation of measurement values.

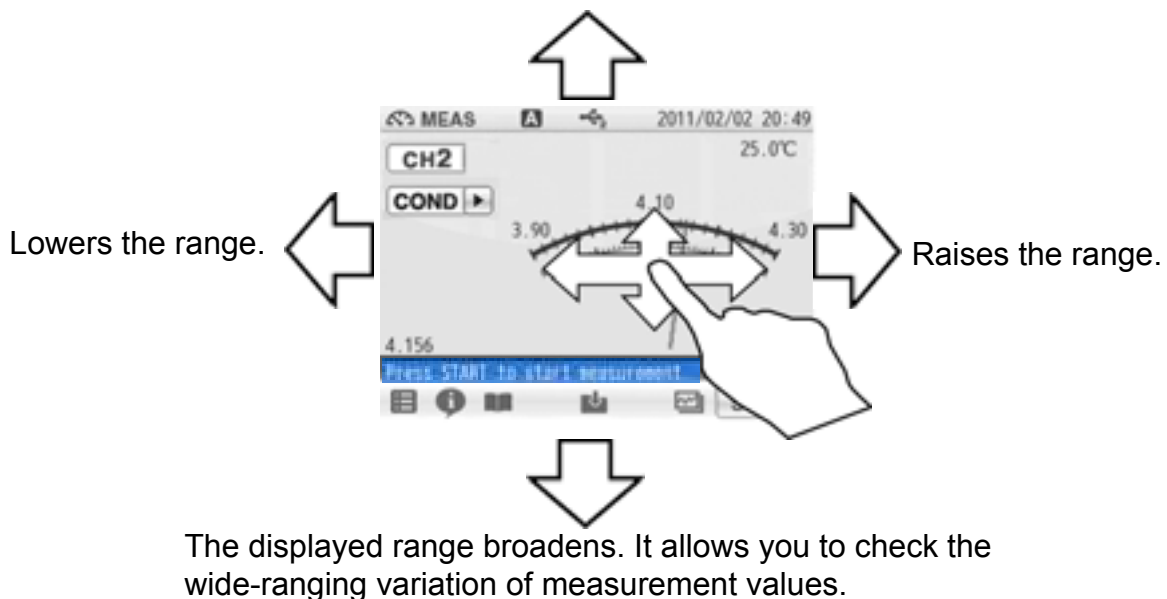

The displayed range broadens. It allows you to check the wide-ranging variation of measurement values.

Tap on the screen after the above operations, and the latest data will be displayed in optimized range.

1.4 Assembling the Electrode Stand

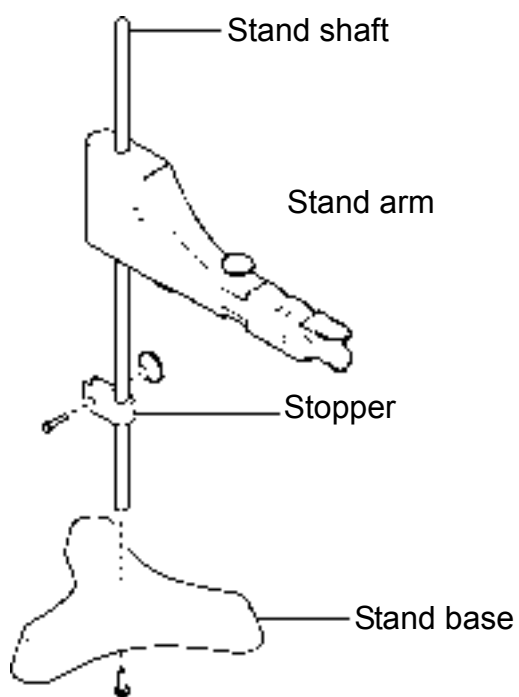

1. Attach the stand shaft to the stand base.
2. Attach the stopper and the stand arm to the stand shaft.

1.5 Connecting the Electrode

1.5.1 Electrode Connector

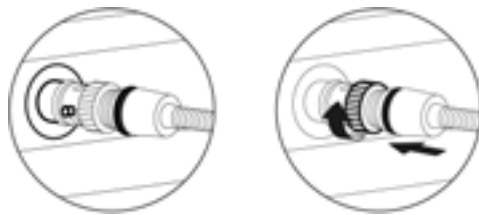
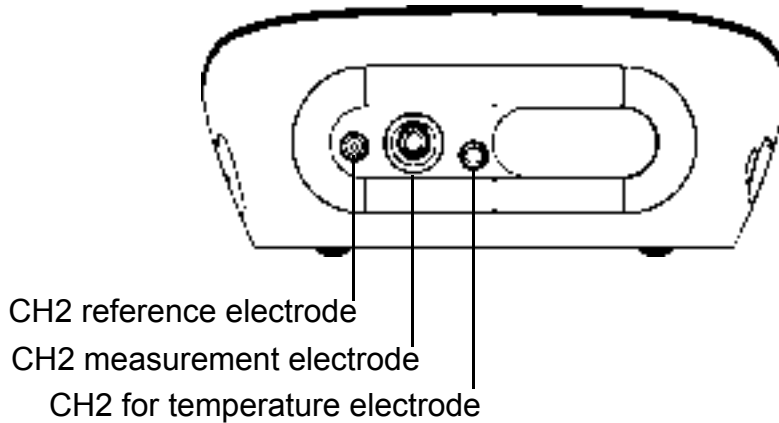

1. Insert the groove of electrode connector by fitting with the connector socket pin of the instrument.

NOTE

Do not insert it with force when the pin and groove are misaligned.

2. Turn the electrode connector to the right along the groove to plug the connector.

3. Put the connector cover on the connector.

NOTE

Just push the cover on the instrument. Do not screw in it.

1.5.2 Temperature Connector



1. Insert the temperature connector into the jack socket on the instrument.

NOTE

If the temperature connector is unconnected or the connection is wrong, the MTC set temperature is displayed as the liquid temperature.

1.6 Connecting the Power Source

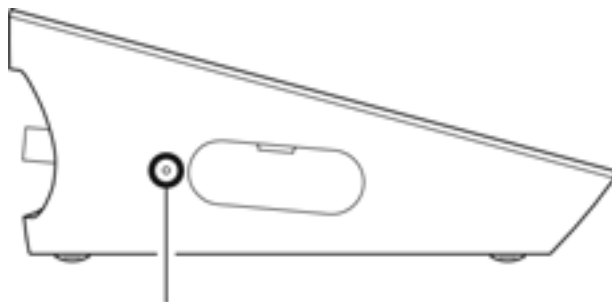

AC adapter connector

1. Insert the AC adapter cable by fitting with the connector socket of in the instrument.

NOTE

- Do not insert the cable with force when the connectors do not match.
 - Attach the provided ferrite core to the AC adapter cable.
-

1.7 Connecting the Printer

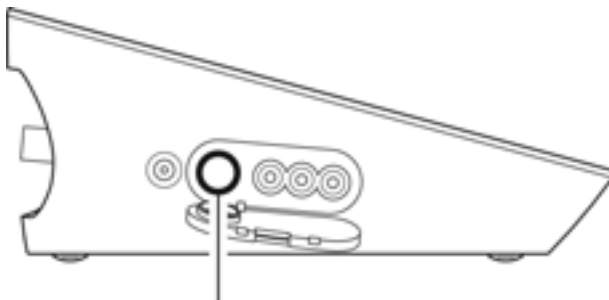

Printer connector

1. Insert the printer cable by fitting with the connector socket of in the instrument.

NOTE

- Do not insert the cable with force when the connectors do not match.
-

The following printer is available.

Printer

CITIZEN CBM-910-24RJ120 V: plain paper type (Parts No.: 3014030146)

CITIZEN CBM-910-24RJ230 V: plain paper type (Parts No.: 3014030147)

Optional printer cable (Parts No.: 3014030148) is required.

NOTE

- Make sure to use the appropriate cable for the printer.
 - Make sure to power OFF the instrument before connecting a printer.
 - When you do not connect a printer with the instrument, disconnect the printer cable and put the rubber cap firmly on the connector socket on the instrument.
-

● Setting the Printer

Refer to the instruction manual of the printer for settings and operations of the printer.

1. Set the DIP switch No. 6 to ON and No. 7 to OFF, and then set printer paper and ink ribbon. Keep the LF key held down.
2. Keep the SEL key held down.
The printer prints output when the SEL key is being pressed.

1.8 Connecting the Personal Computer

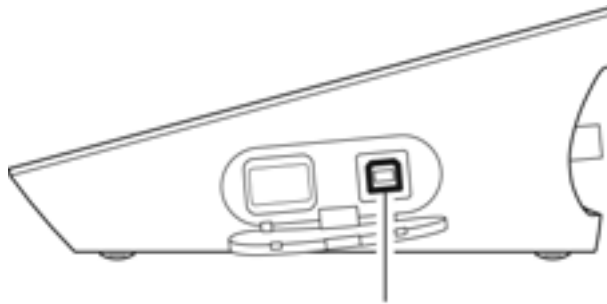

USB connector for personal computer communication

- Use designated cables to connect with a personal computer.
Designated cable
Parts name: USB cable (1 m)
Parts No.: 3200373941
- Make sure that the transfer formats of the measuring instrument and personal computer are same. Otherwise, communication may fail due to a communication error or the online mode start failure. If you change the transfer formats, power OFF both of the instrument and the personal computer once, and then turn ON them again.
- For the details of communication commands, register with our website and see the free download page of manuals.

1.9 Turn ON the Power

Press and hold the POWER key for 2 seconds or longer.
Following the startup screen, the MEAS screen will be displayed.

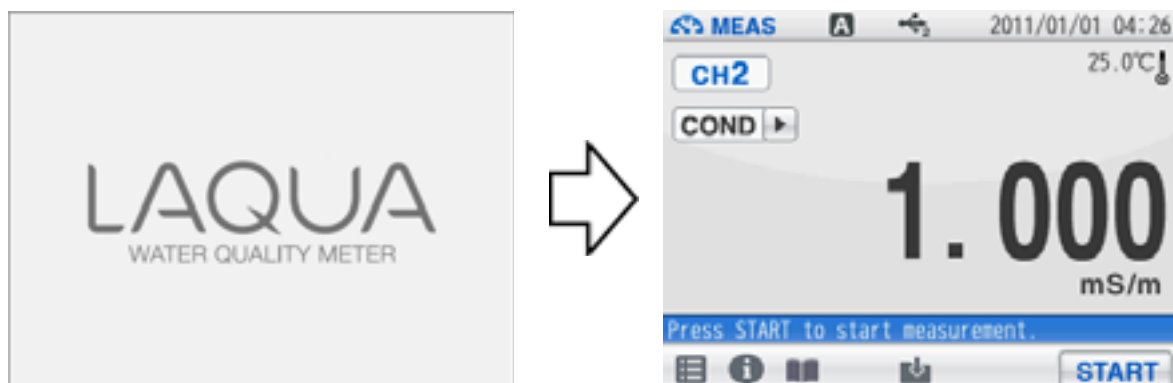

NOTE

- The POWER key does not work for 10 seconds after the AC adapter is connected. Wait for a while after connecting AC adapter.
- If the following message appears on the screen during operation, disconnect the AC adapter and then connect it again and power ON the instrument.

==DS-7X series memory manager==
Exception failure occurred.
Please detach AC adapter and restart.

Chapter 2 Before Measurement (Meter SET)

This chapter explains the procedures of the instrument condition setting, which should be performed before measurement.

2.1 Meter SET Screen

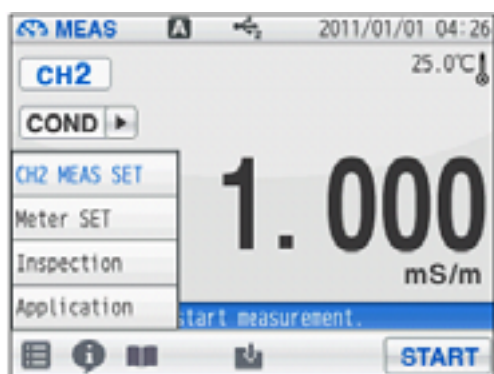



1. Tap  and tap Meter SET.
Meter SET items are displayed.
You will see the remaining items by dragging.
2. Select items and set the conditions.

The setting procedures for each item are explained below.

2.2 Auto Hold Setting



In the AUTO HOLD mode, the instrument judges potential stability automatically to the measurement values. This instrument allows you to select one among the 6 type criteria of potential stability.

1. Change the auto hold settings, tap  on the right of the AUTO HOLD item.
2. Tap  on the right of the HOLD TYPE item.
3. Select the measurement stability condition of the 6 types (EXACT, NORMAL, BRIEF, TIME, CUSTOMIZE, Manual) in the AUTO HOLD selection screen.

To cancel the operation, tap  to return to the previous screen.

Chapter 2 Before Measurement (Meter SET)

Each HOLD condition is described below.

Stability condition		Function			
A	Auto hold	In the AUTO HOLD mode, the instrument judges potential stability automatically to set the measurement values.			
Mode	Measuring target	Content			
		Time (s)	Temperature (°C)	Criteria	【Default】
EXACT	COND, Resist	10	2.0	Minimum display digit: 1 digit	
	SAL			0.30 ppt (0.03%)	
	TDS			10 mg/L	
NORMAL	COND, Resist	10	2.0	Minimum display digit: 3 digit	Default setting of auto hold
	SAL			1.00 ppt (0.10%)	
	TDS			30 mg/L	
BRIEF	COND, Resist	10	2.0	Minimum display digit: 5 digit	
	SAL			3.00 ppt (0.30%)	
	TDS			100 mg/L	
TIME	Common	-	-	Arbitrarily set at 2 s to 999 s.	【10 s】
CUSTOMIZE	COND	Arbitrary setting 2 s to 60 s 【10 s】	2.0	Arbitrarily set at 0.1 mS/m to 10.00 mS/m (0.001 mS/cm to 0.100 mS/cm).	【0.1 mS/m (0.001 mS/cm)】
	SAL			Arbitrarily set at 0.10 PPT to 10.00 PPT (0.01% to 1.00%).	【0.3 PPT (0.03%)】
	Resist			Setting value of COND is reflected.	
	TDS			Arbitrarily set at 0.1 mg/L to 100 mg/L.	【0.1 mg/L】
M	Manual hold	Determine an end point manually. (Tap START to hold it.)			

2.3 Custom Setting



We will explain the procedures of CUSTOMIZE setting taking the AUTO HOLD item as an example.

1. Select the CUSTOMIZE of the Hold type to set the stability condition time and the stability condition value.
2. Use the numeric-key screen to enter measurement variations as HOLD criteria for each measurement item.

Tap  to return to the previous screen.

2.4 Sample Name Setting

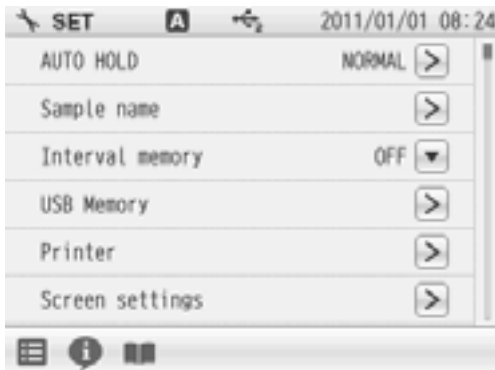

You can set sample names for CH2.

1. Tap on the right of the Sample name item.
2. Tap on the right of the item in the CH2 to enter the sample name.
3. Tap to switch the keyboard entry screen of Alphabet --> Numerical/Symbol. Tap to input in lower-case alphabets. Up to 10 characters can be input.
4. Tap .
The setting applies.
To cancel the settings, tap .
Tap to return to the previous screen.

HINT!

To delete a registered sample name, tap on the right of the sample name, enter nothing, and tap .

2.5 Interval Memory Setting

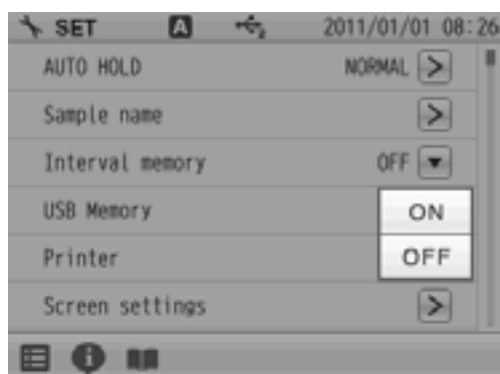



The measured data can be stored at set time intervals.

1. Tap  on the right of the Interval memory item and select ON.

Enter Interval Time



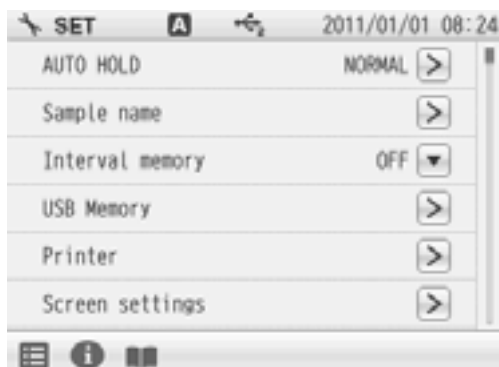

1. Display the Time item when select ON.
Tap  on the right of the Time item.
2. Enter the interval time in the numerical key screen.
(Setting range: 1 to 999 sec.)
3. Tap .
The setting applies.
To cancel the settings, tap .

2.6 USB Memory Setting



Memory data can be written into a USB memory.

1. Tap  on the right of the USB Memory item. The USB memory setting screen is displayed. Tap  to return to the previous screen.

Simultaneously Memory

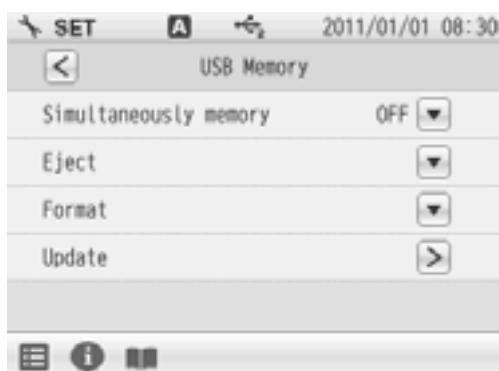



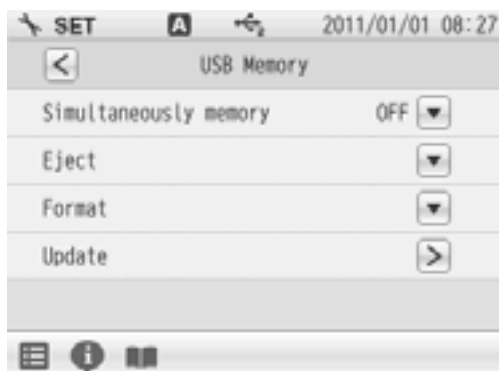

When a USB memory is inserted into the instrument, the data can be written into both the instrument and USB memories at the same time.

1. Tap  on the right of the Simultaneously memory item and select ON.

Eject



Use this item to eject the USB memory from the instrument.

1. Tap  on the right of the Eject item and tap  in the execution confirmation screen. To cancel the operation, tap .
2. When the ejection is completed, a notice message will appear. Tap .



NOTE

If you remove a USB memory from the instrument in a way other than mentioned above, data may not be saved correctly or data may be corrupted.

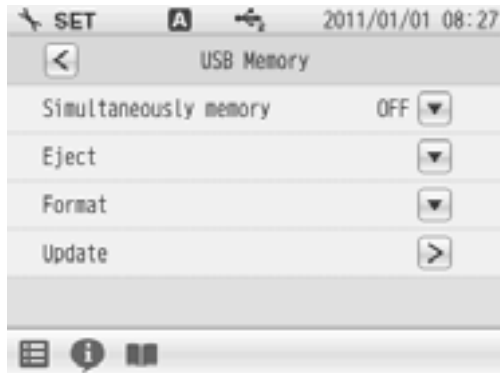
Format



Use this item to format a USB memory in FAT16. Note that formatting deletes all stored data.

1. Tap  on the right of the Format item and tap  in the execution confirmation screen. To cancel the operation, tap .

NOTE

A message that formatting is in progress appears during formatting. Do not remove the USB memory and do not disconnect the instrument power while this message appears. The instrument and USB memory are being accessed.

2. When the format is completed, a notice message will appear. Tap .

2.7 Printer Setting



The Printer item allows you to set printing contents, etc. effective only when a printer is connected with the instrument.

1. Tap on the right of the Printer item. The printer setting screen is displayed. Tap to return to the previous screen.

Printer Test

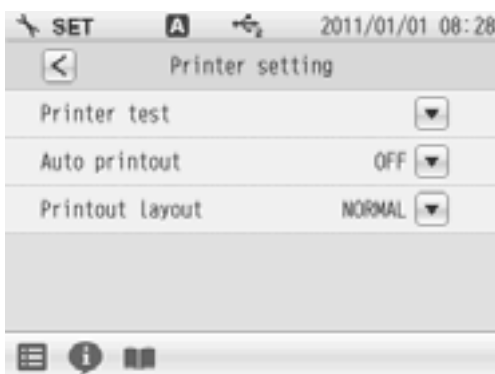

When a printer is connected with the instrument, this item allows you to perform a printer test.

1. Tap on the right of the Printer test item. The printing test is executed. Printout contents

```
!"#$%&'()*+,-./0123
456789:;<=>?@ABCDEFGH
IJKLMNOPQRSTUVWXYZ[
\]^_`abcdefghijklmnop
qrstuvwxyz{|}
```

Auto Printout

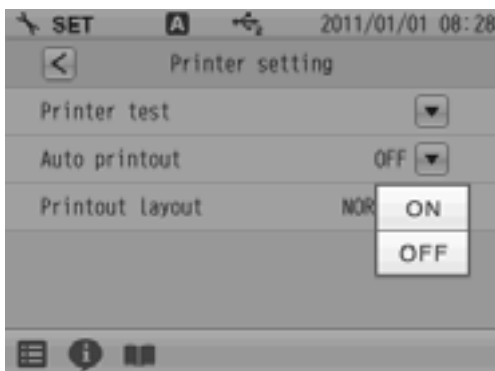

When a printer is connected with the instrument, this item allows you to perform an automatic printer test after measurement or calibration completion.

1. Tap on the right of the Auto printout item and select ON.

Printout Layout

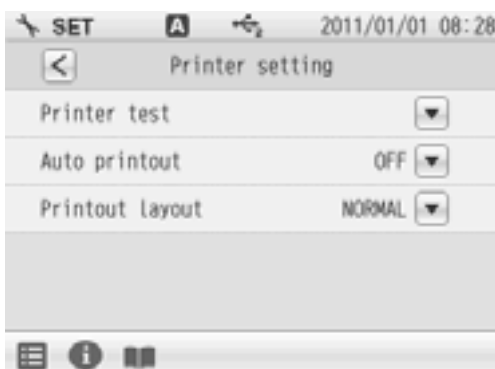

This item allows you to change printing contents.

1. Tap on the right of the Printout Layout item. The printing format screen is displayed. Tap to return to the previous screen.

● When selecting CUSTOMIZE

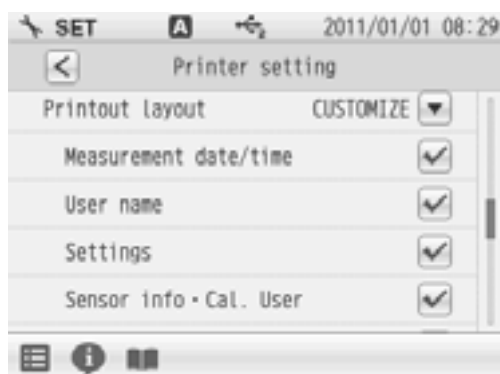

CUSTOMIZE allows you to select items you want to print out among Measurement date/time, User name, Settings, Sensor info•Cal. User.

1. Select CUSTOMIZE from Printout Layout, and tap on the right of the each printing item.
 - is ON: The item is selected.
 - is OFF: The item is not selected.

● Printout example

The following are the examples of BRIEF, NORMAL and GLP printouts.

Contents of results or conditions follows colon mark (:) of each item name.

If they exceeds 10 characters, the exceeded part is displayed on the next line with right alignment.

When selecting CUSTOMIZE, you can select items that you want to print out among the GLP printing contents. But measurement values are always printed.

BRIEF
COND measurement

```
Date      2010 12 18
Time      11 36
COND      1.001mS/cm
HOLD      AUTO
Temperature 25.0 C ATC
```

NORMAL
COND measurement

```
Date      2011 01 07
Time      10 10
COND      1.001mS/cm
HOLD      AUTO
Temperature 25.0 C ATC
Operator   *GUEST*
Sample     COND Sol
Inst model BS-72
Inst SN    1234567
Elect model 3551-100
Elect lot  1234567
Temp Coef  2.00% C
Cal Operator *GUEST*
```

GLP (CUSTOMIZE)
COND measurement



```
GLPFormat
Date      2011 01 07
Time      10 10
COND      1.001mS/cm
HOLD      AUTO
Temperature 25.0 C ATC
Operator   *GUEST*
Sample     COND Sol
Inst model BS 72
Inst SN    1234567
Elect model 3551-100
Elect lot  1234567
Cell
Temp Coef  1.00% x 10^-1
Cal Operator *GUEST*
Calibration data
Cal data   2011 01 01
Cal Time   10 00
Signature
```

Measurement date
Measurement value
(Not be omitted)
Measurement operator
Settings
Electrode
Calibration operator
Calibration data
Signature

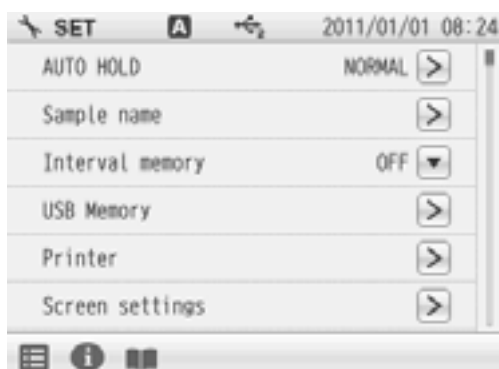
2.8 Screen Settings





You can change screen settings.

1. Tap  on the right of the Screen settings item. The screen settings screen is displayed.
Tap  to return to the previous screen.

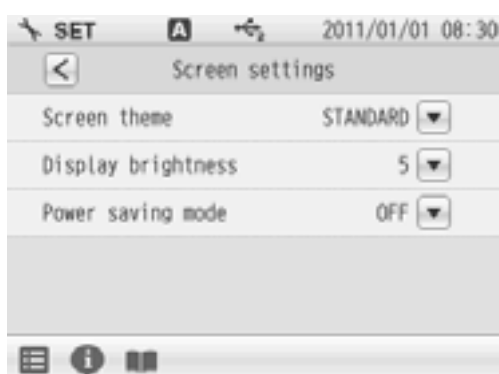
Screen Theme





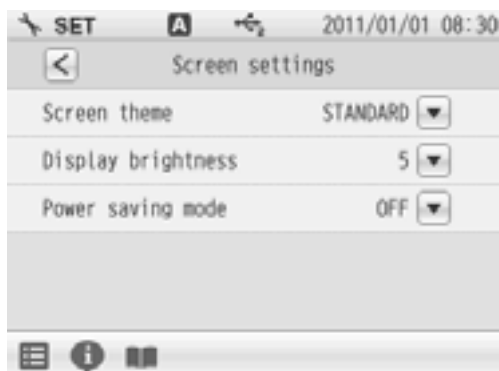

You can select one among 4 type screen themes; STANDARD, COOL, MONOTONE and KYOTO.

1. Tap  on the right of the Screen theme item.
2. Select screen theme.
To cancel the operation, tap  to return to the previous screen.

Display Brightness



You can adjust the display brightness by tapping  or , or by dragging on the scale.

1. Tap  on the right of the Display brightness item.
2. When the screen becomes the desired brightness, tap .
To cancel the operation, tap  to return to the previous screen.

Power Saving Mode

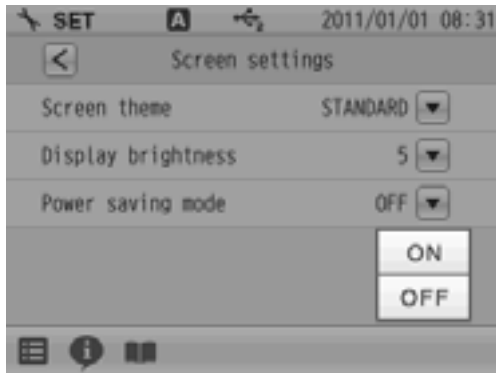



You can set the time for power saving mode.

1. Tap  on the right of the Power saving mode item and select ON.

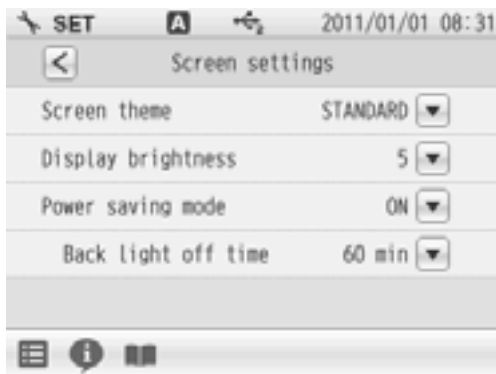
● Back light off time



When selecting ON for Power saving mode, the Back light off time item is displayed.

1. Tap  on the right of the Back light off time item.
2. Enter the desired time on the numerical key screen. (Setting range: 1 to 999 minutes)
3. Tap  .
The set time applies.
To cancel the settings, tap  .



HINT!

During the power saving mode, the LED lamp above the POWER key lights up. Press the POWER key to exit the power saving mode.

2.9 Sound Setting





You can change sound settings.

1. Tap  on the right of the Sound settings item. The sound settings screen is displayed.
Tap  to return to the previous screen.

Sound Theme





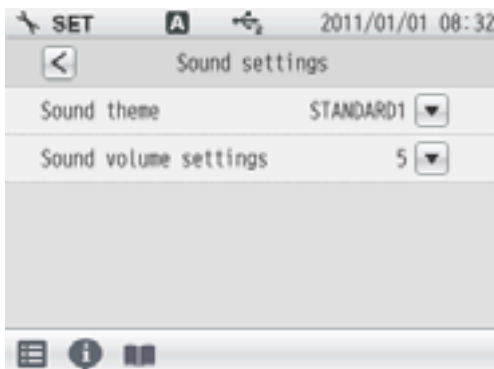

You can select one among 4 type sound themes; STANDARD, COOL, MONOTONE and KYOTO.

1. Tap  on the right of the Sound theme item.
2. Select sound theme.
To cancel the operation, tap  to return to the previous screen.

Volume Setting





You can adjust the sound volume by tapping  or , or by dragging on the scale. When the sound volume is set to 0, the instrument is in the mute mode.

1. Tap  on the right of the Sound volume settings item.
2. When the screen becomes the desired volume, tap .
To cancel the operation, tap  to return to the previous screen.

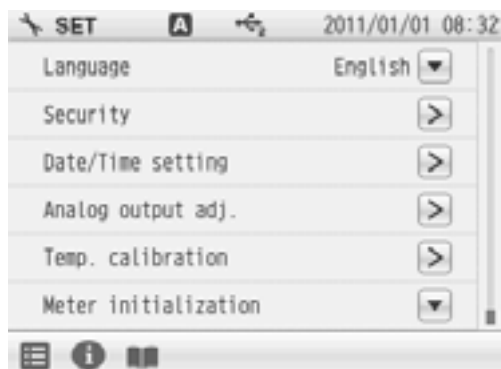
2.10 Language Setting





You can change language settings.

1. Tap  on the right of the Language item.
2. Select the language.
To cancel the operation, tap .

2.11 Security Setting



Security setting allows you to set a password for an administrator of the instrument. After the setting is ON, the instrument requires you to select an operator name at the startup. Security setting, Date/Time setting, Analog output adj., Temp. calibration and Meter initialization are restricted to the administrator. To change the administrator or operator when the Security setting is ON, power OFF the instrument. At the next startup, the user selection screen appears to allow you to change it. 25 administrators or operators in total can be registered.

1. Tap  on the right of the Security item.
The User management screen is displayed.
To cancel the operation, tap  to return to the previous screen.
2. Tap  on the right of the User management item and select ON.

When using the Security setting, administrator registration is required.



1. Tap the blank area at the right of "User name" to display the letter entry screen.
2. Enter the operator name, and tap **ENTER**.
Tap the **A1** to switch the keyboard entry screen of Alphabet and Numerical/Symbol. Tap the **SHIFT** to input in lower-case alphabets. Up to 12 characters can be input.
3. Tap the blank area at the right of "Password" to display the numerical screen.
4. Enter the password, and tap **ENTER**.
The password can be set between 2 and 10 characters.
5. Tap **ENTER** to set.

NOTE

When the Security setting is ON, at least 1 administrator is required for the instrument. Administrators have to keep the password. We recommend registering 2 or more administrators.

Administrator's names are marked with a star on the user selection screen.

2.12 User Entry/Info Change/Delete

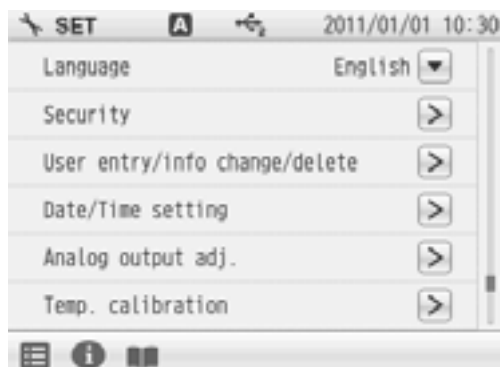

When an operator is registered, the operator name can be put in measurement/calibration information, data printouts, data memory.

1. Tap on the right of the User entry/info change/delete item, when user registration, change password and user deletion.
The User entry/info change/delete screen is displayed.

To cancel the operation, tap to return to the previous screen.

User Registration

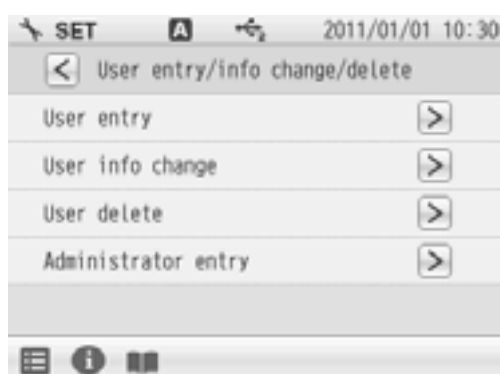

You can register operators.

1. Tap on the right of the User entry item.
2. Tap the blank area at the right of "User name" to display the letter entry screen.
3. Enter the operator name, and tap .
Tap the to switch the keyboard entry screen of Alphabet and Numerical/Symbol.
Tap the to input in lower-case alphabets.
Up to 12 characters can be input.
4. Tap the blank area at the right of "Password" to display the numerical screen.
5. Enter the password, and tap .
The password can be set between 2 and 10 characters.
6. Tap to set.

NOTE

When the Security setting is ON, at least 1 administrator is required for the instrument. Administrators have to keep the password. We recommend registering 2 or more administrators.
Administrator's names are marked with a star on the user selection screen.

User Information Changing

Operators can change the password.

1. Tap on the right of the User info change item.
2. Enter the password, and tap .
3. Tap the current password at the right of "Password" to display the numerical-key screen.
4. Enter the password, and tap . The password can be set between 2 and 10 characters.

User Deleting

Only administrators can deregister an operator.

1. Tap on the right of the User delete item.
2. Tap on the right of the operator item.
3. Tap . Tap , when do not deleting.

Administrator Registration

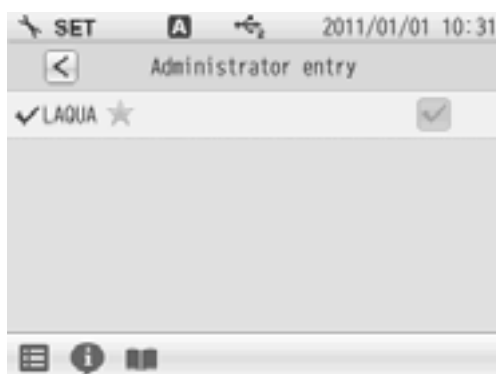

Only administrators can assign/remove an operator as an administrator.

1. Tap on the right of the Administrator entry item.
2. Tap to add a new administrator at the Administrator entry screen. Then, the lights up to show it is in the state of being selected. Tap to change the current administrator to operator. At this time, the lights out to show it is in the state of being unselected.

NOTE

When the Security setting is ON, at least 1 administrator is required for the instrument. Administrators have to keep the password. We recommend registering 2 or more administrators.

Administrator's names are marked with a star on the user selection screen.

2.13 Date Setting



You can set the date and time.

1. Tap on the right of the Date/Time setting item.
The Date/Time setting screen is displayed.
Tap to return to the previous screen.

Date

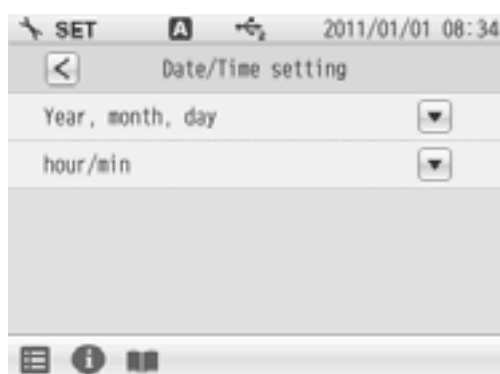

You can set the date.

1. Tap on the right of the Year, month, day item.
 2. Tap or to set the date.
 3. Tap .
- To cancel the operation, tap to return to the previous screen.

Time

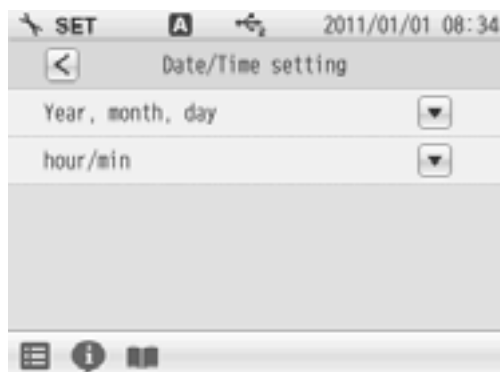



You can set the time.

1. Tap on the right of the hour/min item.
 2. Tap or to set the time.
 3. Tap .
- To cancel the operation, tap to return to the previous screen.

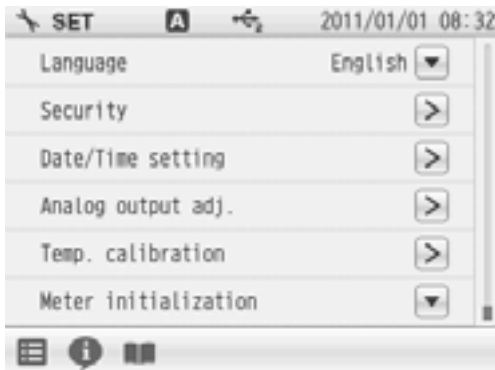
2.14 Analog Output Adjustment







Voltage output can be acquired from the analog output connector located at the instrument side

1. Tap  on the right of the Analog output adj. item.
The Analog output adj. screen is displayed.
Tap  to return to the previous screen.

How to Analog Output Adj.





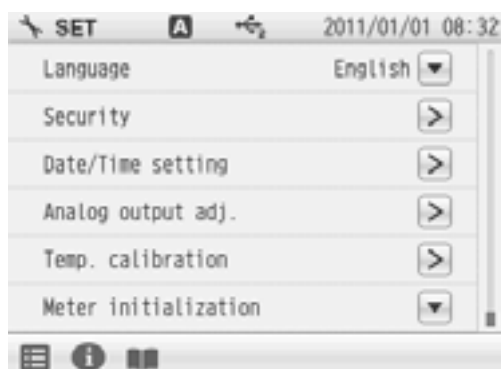

Connect the instrument with a digital multimeter, digital recorder, pen recorder or the like using an designated cable (analog output cable: Parts No.3014030152), and check and adjust the analog output value of the instrument.

1. Tap  on the right of the analog output item.
The Output value adjustment screen is displayed.
 2. Tap  or  to adjust the analog output voltage.
 3. Tap .
- To cancel the operation, tap  to return to the previous screen.

2.15 Temperature Sensor Calibration





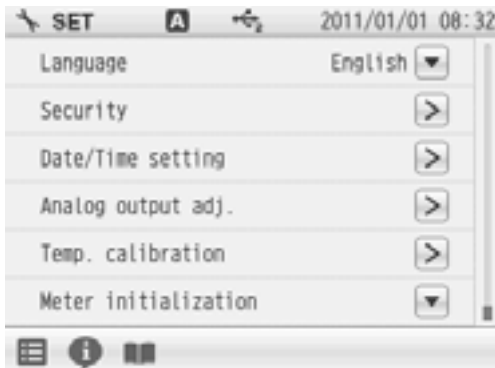

You can perform calibration of the temperature sensor.

1. Tap  on the right of the Temp. calibration item.
The Temp. calibration setting screen is displayed.
To cancel the operation, tap  to return to the previous screen.
2. Display the measured temperature by the temperature sensor connected to the instrument.
Display "-----", when not connecting the temperature sensor.
3. Tap  on the right of the temperature sensor's channel item.
4. Enter the temperature with the numerical screen and tap .
Tap  when do not reflect the setting.

2.16 Resetting to Factory Defaults



You can reset the instrument to the factory default conditions.

1. Tap  on the right of the Meter initialization item.
2. Tap  in the execution confirmation screen. Tap , when do not resetting.
3. Display the confirmation screen again, and tap . Tap , when do not resetting.
4. Restart after the Meter initialization was finished. Press the POWER key to turn OFF.
5. Press and hold the POWER key for 2 seconds to turn ON.

NOTE

If you disconnect the AC adapter after powering OFF, the POWER key does not work for 10 seconds after the AC adapter is reconnected. Wait for a while after reconnecting AC adapter.

Chapter 3 COND (conductivity) Measurement





3.1 COND Calibration Setting

This section describes the procedures to set the conditions of COND calibration. Set the conditions of resolution and temperature compensation before COND calibration according to "3.2 COND Measurement Setting" (P.36).

The cell constants of COND electrodes are different. Set the cell constant written on the electrode into the instrument before use.

3.1.1 Cell Constant Setting



1. Tap the channel setting and the measurement item in the MEAS screen to set "CH2" and "COND".
2. Press the CAL key and tap "Set Cell Constant". The cell constant setting screen is displayed.
3. Tap the left side numerical value to display the numerical screen.
4. Enter the numerical value written on the COND electrode. The entered value applies.
5. Tap  or  to enter the digit written on the COND electrode.
6. Tap . Reflect the setting. To cancel the settings, tap .

NOTE

The unit indication of the cell constant depends on the electrode. Convert the unit to the one for the meter before input.

$$100 \text{ m}^{-1} = 1 \text{ cm}^{-1}$$

$$1000 \text{ m}^{-1} = 10 \text{ cm}^{-1}$$

$$10 \text{ m}^{-1} = 0.1 \text{ m}^{-1}$$



3.1.2 Calibration of Standard Solution

A verified cell constant is written on a COND electrode label.

However, the actual cell constant may fluctuate depending on the usage circumstances and it is desirable to calibrate the cell constant in that case.

The procedures of cell constant calibration are mentioned below.

NOTE

- Perform "3.1.1 Cell Constant Setting" (P.34), before the following operations.
- Tapping  on the COND CAL screen allows you to check the current calibration data.
To clear the calibration data, tap .

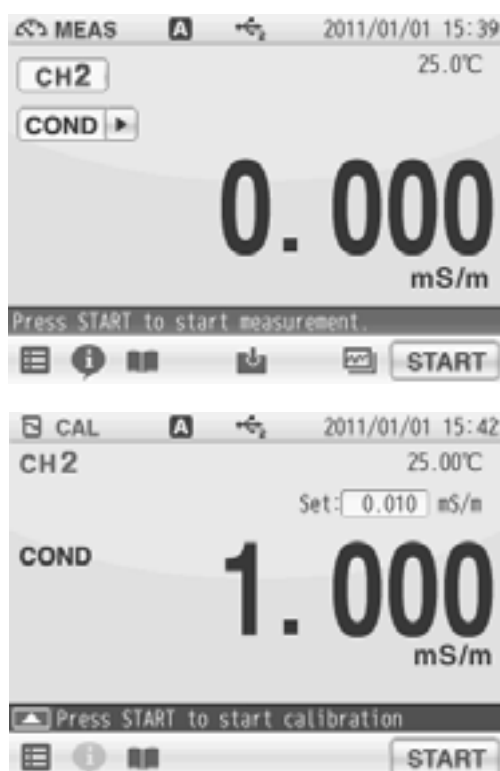

1. Tap the channel setting and the measurement item in the MEAS screen to set "CH2" and "COND".
2. Press the CAL key and tap "Cal. Std. sol".
The Select method for COND CAL screen is displayed.
3. Tap the COND value at the right of "Set:" to display the numerical-key screen.
4. Enter the conductivity value of the standard solution to be used for calibration, and tap **ENTER**.
5. Tap **mS/m** to select the auxiliary unit of standard solution.
Each tapping switches the unit S/m --> ms/m.
6. Tap **ENTER**.
The conductivity value of standard solution used for calibration applies.
7. Tap **START** to start the calibration.
When the calibration is completed, the HOLD indicator is lit up and the calibration result is displayed.
8. After checking the calibration result, tap **CLOSE** to return to the CAL screen.
9. To start COND measurement, press the MEAS key.

NOTE

- Make sure that the temperatures of the standard solution and electrode are stable before the above operations. If you perform the operations with unstable temperatures, the calibration result may be incorrect.
- Immerse the electrode into the standard solution at the proper depth and stir it slowly with a stirrer. Do not return the used standard solutions into the original container. Dispose of them.

3.2 COND Measurement Setting

This section describes the procedures to set the conditions of COND measurement.



1. Tap the channel setting and the measurement item in the MEAS screen to set "CH2" and "COND".
2. Tap  and tap "CH2 MEAS SET".
3. COND measurement setting items are displayed. You will see the remaining items by dragging.
4. Select items and set the conditions.

The setting procedures for each item are explained below.

3.3 COND Measurement Unit Setting

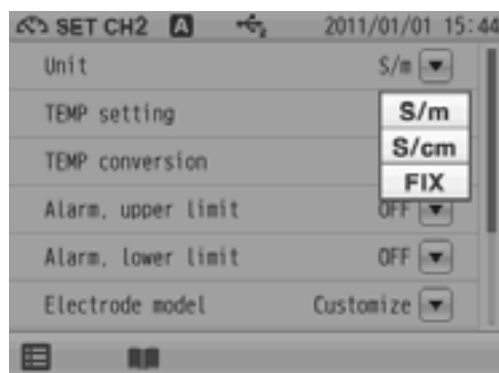

You can select S/m, S/cm or FIX (Unit is fixed at mS/cm as the COND measurement unit).

1. Tap  on the right of the Unit item.
2. Select S/m, S/cm or FIX. The selected unit applies.

3.4 Temperature Setting

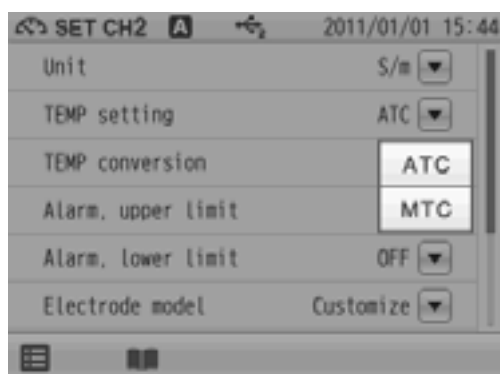

There are two types of temperature setting for COND measurement; Automatic Temperature Compensation (ATC) and Manual Temperature Compensation (MTC).

In ATC, the instrument detects the solution temperature with the connected temperature sensor, and performs temperature compensation for the COND values of the standard solutions used for calibration.

In MTC, measure the solution temperature and enter the value in advance. The instrument performs temperature compensation using the entered temperature.

NOTE

If the temperature terminals of the instruction and electrode are not connected, temperature setting is performed in MTC even when ATC is set.

3.4.1 Solution Temperature Entry in MTC (Manual Temperature Compensation)

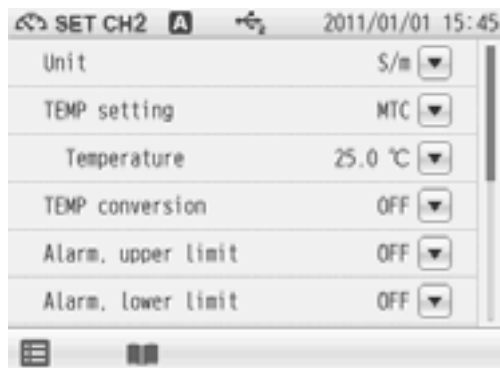

1. Display the Temperature item when select MTC.
Tap on the right of the Temperature item.
2. Enter the solution temperature on the numerical-key screen.
3. Tap .
The setting applies.
To cancel the settings, tap .

3.5 Temperature Conversion Function Setting

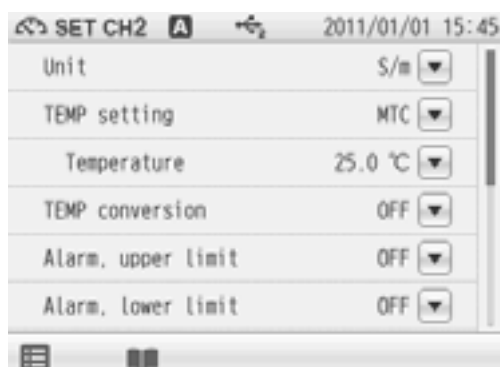

The measured COND value of a sample varies with the temperature. In addition, the change degree with temperature depends on the sample property.

If the change degree (temperature coefficient) of the sample is known, set this item to ON to display COND values converted at 25°C.

If the temperature coefficient is unknown, set this item to OFF.

1. Tap  on the right of the TEMP conversion item.
2. Select the temperature conversion method.

HINT!





When select the pure water mode or the natural water mode, the temperature conversion conforms to the following standards.

Pure water: ASTM D 1125-91 Table3

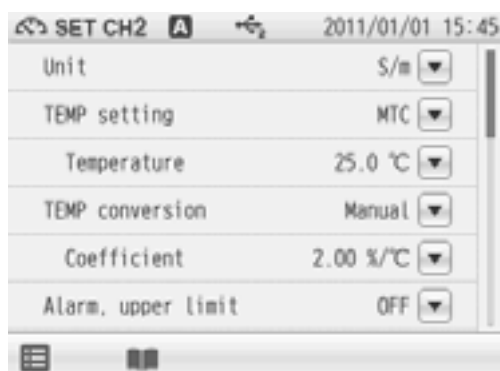
Natural water: ISO7888:1985 (JIS K0400-13-10:1999)

3.5.1 Input Temperature Conversion Factor



1. Tap  on the right of the TEMP conversion item.
2. Select "Manual" on the TEMP conversion screen.
3. Tap  on the right of the Coefficient item.
4. Enter the temperature conversion factor on the numerical-key screen.
5. Tap  .
The setting applies.
To cancel the settings, tap  .

3.6 Alarm Setting

When the measurement values exceeds the set upper or lower limit, the instrument detects it to display the notice on the screen or to output the signal from the external output terminal.

If the measurement values exceeds the alarm range, the color of the pertinent channel "CH" is changes on the MEAS screen.

Set the upper limit alarm to ON for the upper limit control of measurement value.

Set the lower limit alarm to ON for the lower limit control of measurement value.

Upper limit value

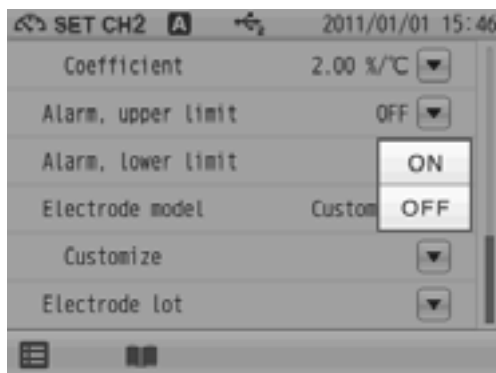



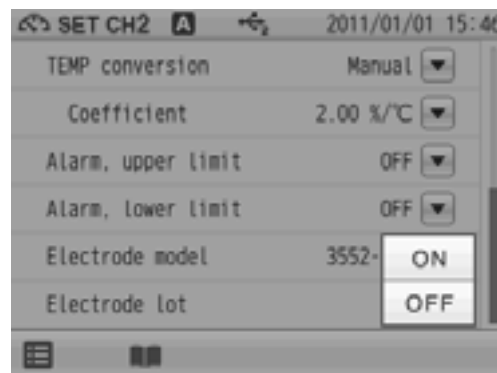

Lower limit value

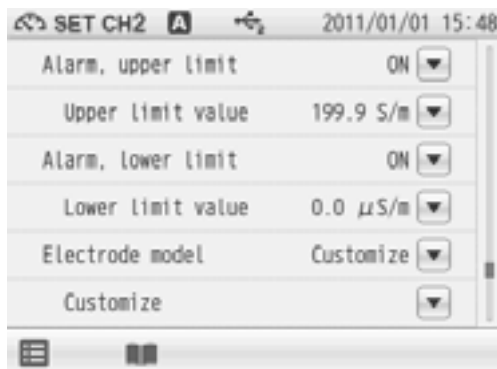

3.6.1 Input Upper or Lower Limit Values



Upper limit value entry

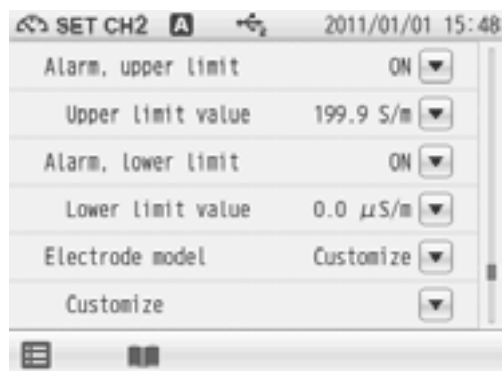

1. When selecting ON the Alarm, upper limit item, the Upper limit value, tap  on the right of the Upper limit value item.
2. Enter an upper limit value on the numerical-key screen.
To change the unit (mS/m, μS/m, etc.), tap on the unit change key on the right of the numerical-key screen.
3. Tap .
The setting applies.
To cancel the settings, tap .

Lower limit value entry



1. When selecting ON the Alarm, lower limit item, the Lower limit value, tap  on the right of the Lower limit value item.
2. Enter an upper limit value on the numerical-key screen.
To change the unit (mS/m, μ S/m, etc.), tap on the unit change key on the right of the numerical-key screen.
3. Tap .
The setting applies.
To cancel the settings, tap .

NOTE

Even if changing units (S/m, S/cm, FIX), the alarm set value is not changed.

3.7 Electrode Model Setting

When an electrode model is set, the model name can be displayed on data printouts or recorded in saved data.

Select the electrode model to be used for measurement.

You can set a desired name with up to 10 characters by selecting the Customize item.

3.7.1 Electrode Model Selection

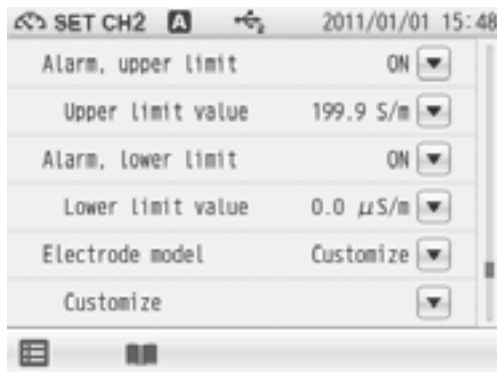

1. Tap on the right of the Electrode model item. The electrode model selection screen appears. To cancel the settings, tap .
2. Select the electrode model to be use. Tap an electrode model name, and the selected model applies.

3.7.2 Electrode Model Entry

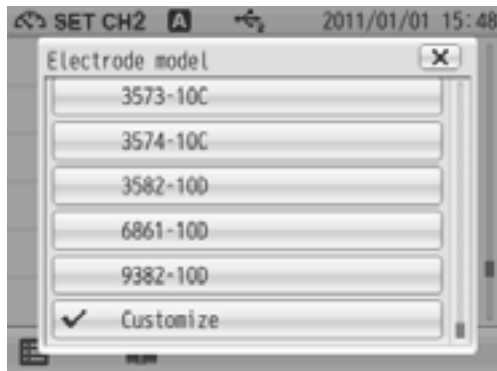

You can set a desired name with up to 10 characters.

1. Tap "Customize" in the electrode model selection screen.
2. When selecting Customize for the Electrode model item, the Customize item is displayed. Tap on the right of the Customize item.
3. Enter an electrode model name using the keyboard screen. Tap to switch the keyboard entry screen of Alphabet --> Numerical/Symbol. Tap to input in lower-case alphabets. Up to 10 characters can be input.
4. Tap . The setting applies. To cancel the settings, tap .



HINT!

To delete a registered electrode model name, tap on the right of the electrode model name, enter nothing, and tap .

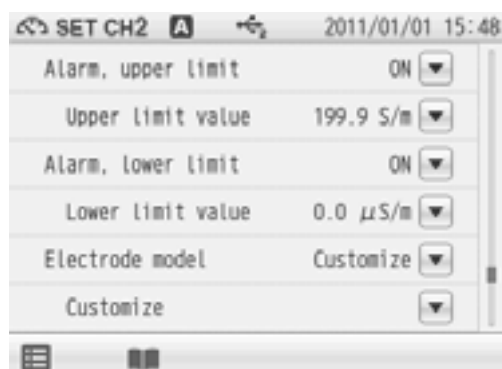
3.8 Electrode Lot No. Setting



When an electrode lot No. is entered, the lot No. can be displayed on data printouts or recorded in saved data.

1. Tap  on the right of the Electrodelot item.
2. Enter the electrode lot No. on the numerical-key screen.
Up to 8 digits can be entered.
To cancel the settings, tap .

HINT!

To delete a registered electrode model name, tap  on the right of the electrode model name, enter nothing, and tap **ENTER**.

3.9 COND Measurement

This section describes the procedures of COND measurement.



1. Press the MEAS key, and tap the channel setting and the measurement item in the MEAS screen to set "CH2" and "COND".

2. Tap **START** to start measurement. The measurement value is displayed, and the HOLD indicator blinks until the reading stabilizes.

To stop calibration tap **STOP** while the HOLD indicator blinks.

When the reading stabilizes, the value is held and HOLD indicator lights up.

During instantaneous value measurement, or when a measurement value is held, you can store the measurement values by tapping  on the bottom of the screen.

3. After the measurement is completed, tap **STOP** to proceed to the next measurement.

Chapter 4 SAL (Salinity) Measurement



4.1 SAL Calibration Setting

This section describes the procedures to set the conditions of SAL calibration.

A SAL (salinity) value is obtained by conversion of a COND (conductivity) value. However, you can perform calibration using standard solutions.

Make sure to perform the calibration at the temperature specified on the standard solution label. The procedures are mentioned below.

NOTE

- Before SAL calibration, do the unit settings of "3.1.1 Cell Constant Setting" (P.34) and "4.2 SAL Measurement Setting" (P.45).
- Tapping  on the SAL CAL screen allows you to check the current calibration data. To clear the calibration data, tap .



1. Tap the channel setting and the measurement item in the MEAS screen to set "CH2" and "SAL".
2. Press the CAL key to display the SAL CAL screen.
3. Wash the COND electrode with pure water (ion exchange water), and wipe it off by filter paper or tissue paper.
4. Open the internal solution filler port of the COND electrode.
5. Immerse the COND electrode into a beaker of the standard solution.
6. Tap the numerical value at the right of "Set:" to display the numerical-key screen.
7. Enter the salinity value of standard solution, and tap **ENTER**.
The conductivity value of standard solution used for calibration applies.
8. Tap **START** to start the calibration.
When the calibration is completed, the HOLD indicator is lit up and the calibration result is displayed.
9. Tap **CLOSE** after checking the calibration result to return to the CAL screen.
To start SAL measurement, press the MEAS key.

4.2 SAL Measurement Setting

This section describes the procedures to set the conditions of SAL measurement.

Salinity concentration is calculated (Practical Salinity Scale (UNESCO 1978)) from the measured value of conductivity.

Therefore, when the cell constant is set in conductivity measurement, there is no need to input the cell constant. If no cell constant is set, refer to "3.1.1 Cell Constant Setting" (P.34).



1. Tap the channel setting and the measurement item in the MEAS screen to set "CH2" and "SAL".
2. Tap  and tap "CH2 MEAS SET".
The SAL measurement setting items are displayed.
3. Select items and set the conditions.

The setting procedures for each item are explained below.

4.3 SAL Measurement Unit Setting

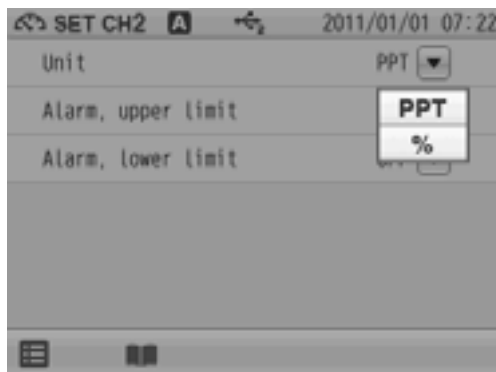

The measurement unit of SAL measurement values select either PPT or %.

1. Tap  on the right of the Unit item.
2. Select PPT or %.
The selected unit applies.

4.4 Temperature Setting

The settings of temperature compensation and temperature conversion in COND measurement apply for SAL measurement (refer to "3.4 Temperature Setting" (P.37) and "3.5 Temperature Conversion Function Setting" (P.38)).

4.5 Alarm Setting

When the measurement values exceeds the set upper or lower limit, the instrument detects it to display the notice on the screen or to output the signal from the external output terminal.

If the measurement values exceeds the alarm range, the color of the pertinent channel "CH" is changes on the MEAS screen.

Set the upper limit alarm to ON for the upper limit control of measurement value.

Set the lower limit alarm to ON for the lower limit control of measurement value.

Upper limit value

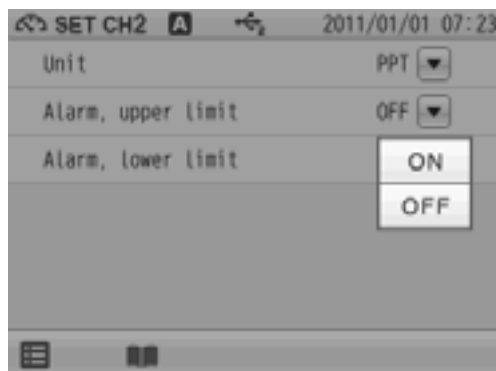



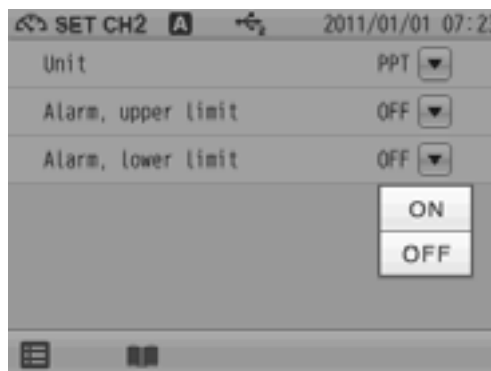

Lower limit value

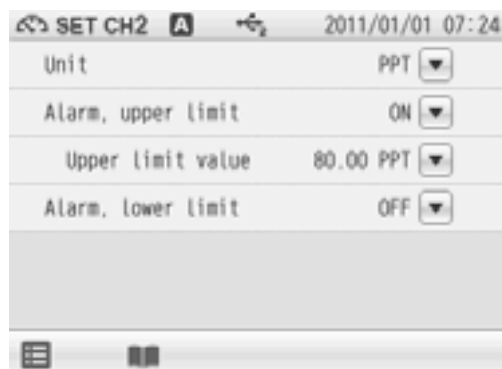

4.5.1 Input Upper or Lower Limit Values



Upper limit value entry

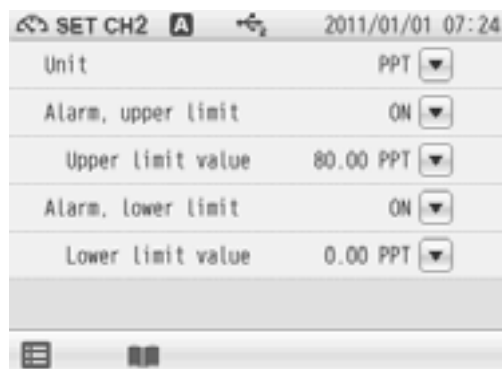

1. When selecting ON the Alarm, upper limit item, the Upper limit value, tap  on the right of the Upper limit value item.
2. Enter an upper limit value on the numerical-key screen.
3. Tap . The setting applies. To cancel the settings, tap .

Lower limit value entry



1. When selecting ON the Alarm, lower limit item, the Lower limit value, tap  on the right of the Lower limit value item.
2. Enter an upper limit value on the numerical-key screen.
3. Tap . The setting applies. To cancel the settings, tap .

4.6 Electrode Model Setting

The electrode model setting in COND measurement applies for SAL measurement (refer to "3.7 Electrode Model Setting" (P.41)).

4.7 SAL Measurement

This section describes the procedures of SAL measurement.



1. Press the MEAS key, and tap the channel setting and the measurement item in the MEAS screen to set "CH2" and "SAL".

2. Tap **START** to start measurement.

The measurement value is displayed, and the HOLD indicator blinks until the reading stabilizes.

To stop calibration tap **STOP** while the HOLD indicator blinks.

When the reading stabilizes, the value is held and HOLD indicator lights up.

During instantaneous value measurement, or when a measurement value is held, you can store the measurement values by tapping  on the bottom of the screen.

3. After the measurement is completed, tap **STOP** to proceed to the next measurement.

Chapter 5 Resist (Resistivity) Measurement

This section describes the procedures to set the conditions of Resist measurement.

5.1 Resist Measurement Setting



1. Tap the channel setting and the measurement item in the MEAS screen to set "CH2" and "Resist".
2. Tap  and tap "CH2 MEAS SET".
The Resist measurement setting items are displayed.
3. Select items and set the conditions.

The setting procedures for each item are explained below.

5.2 Resist Measurement Unit Setting

The measurement units ($\Omega\cdot\text{m}$ or $\Omega\cdot\text{cm}$) of the Resist measurement values are reflecting the setting units (S/m or S/cm) of COND measurement setting ("3.3 COND Measurement Unit Setting" (P.36)).

5.3 Temperature Setting

The settings of temperature compensation and temperature conversion in COND measurement apply for Resist measurement (refer to "3.4 Temperature Setting" (P.37) and "3.5 Temperature Conversion Function Setting" (P.38)).

5.4 Alarm Setting

When the measurement values exceeds the set upper or lower limit, the instrument detects it to display the notice on the screen or to output the signal from the external output terminal.

If the measurement values exceeds the alarm range, the color of the pertinent channel "CH" is changes on the MEAS screen.

Set the upper limit alarm to ON for the upper limit control of measurement value.

Set the lower limit alarm to ON for the lower limit control of measurement value.

Upper limit value

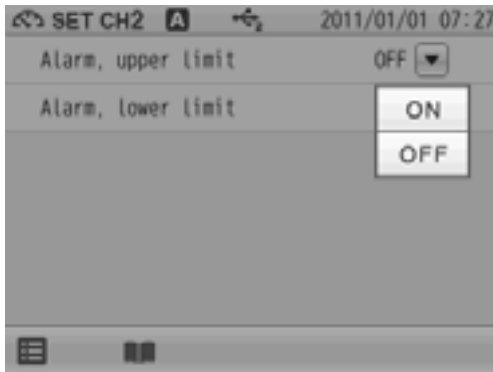



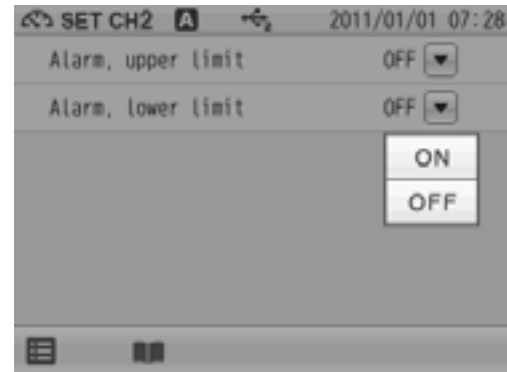

Lower limit value

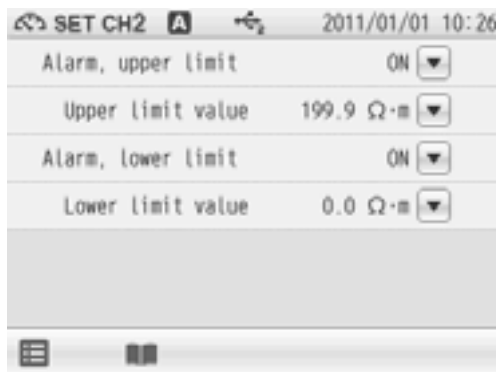

5.4.1 Input Upper or Lower Limit Values



Upper limit value entry

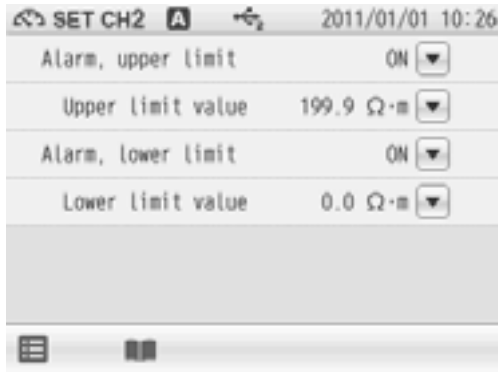

1. When selecting ON the Alarm, upper limit item, the Upper limit value, tap  on the right of the Upper limit value item.
2. Enter an upper limit value on the numerical-key screen.
To change the unit ($M\Omega\cdot m$, $k\Omega\cdot m$ etc.), tap on the unit change key on the right of the numerical-key screen.
3. Tap .
The setting applies.
To cancel the settings, tap .

Lower limit value entry



1. When selecting ON the Alarm, lower limit item, the Lower limit value, tap  on the right of the Lower limit value item.
2. Enter an upper limit value on the numerical-key screen.
To change the unit ($M\Omega\cdot m$, $k\Omega\cdot m$ etc.), tap on the unit change key on the right of the numerical-key screen.
3. Tap .
The setting applies.
To cancel the settings, tap .



5.5 Electrode Model Setting

The electrode model setting in COND measurement applies for Resist measurement (refer to "3.7 Electrode Model Setting" (P.41)).

5.6 Resist Measurement

This section describes the procedures of Resist measurement.



1. Press the MEAS key, and tap the channel setting and the measurement item in the MEAS screen to set "CH2" and "Resist".
2. Tap  to start measurement.
The measurement value is displayed, and the HOLD indicator blinks until the reading stabilizes.
To stop calibration tap  while the HOLD indicator blinks.
When the reading stabilizes, the value is held and HOLD indicator lights up.
During instantaneous value measurement, or when a measurement value is held, you can store the measurement values by tapping  on the bottom of the screen.

Chapter 6 TDS (Total Dissolved Solids) Measurement

This section describes the procedures to set the conditions of TDS measurement.

6.1 TDS Measurement Setting



1. Tap the channel setting and the measurement item in the MEAS screen to set "CH2" and "TDS".
2. Tap  and tap "CH2 MEAS SET".
The TDS measurement setting items are displayed.
3. Select items and set the conditions.

The setting procedures for each item are explained below.

6.2 TDS Measurement Mode Setting

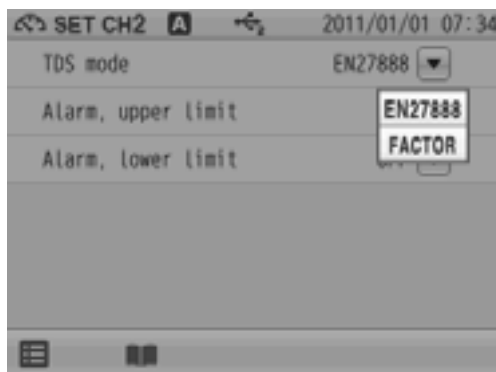



Select a TDS measurement mode (EN27888 compliant or using a set factor).

1. Tap  on the right of the TDS item.
2. Select EN27888 or FACTOR.
The selected unit applies.

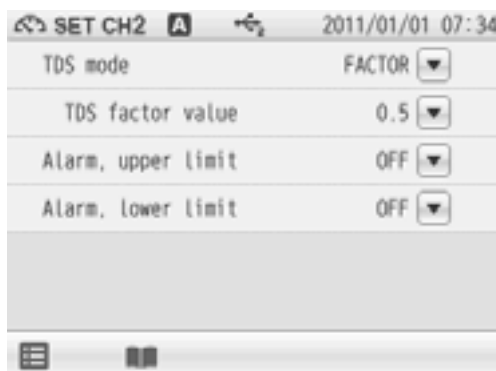
6.2.1 Input TDS Factor Value when Select FACTOR



1. Display the TDS mode item when select FACTOR.
Tap  on the right of the TDS factor value item.
2. Enter the TDS factor value on the numerical-key screen and tap .
The setting applies.
To cancel the settings, tap .

6.3 Temperature Setting

The settings of temperature compensation and temperature conversion in COND measurement apply for TDS measurement (refer to "3.4 Temperature Setting" (P.37) and "3.5 Temperature Conversion Function Setting" (P.38)).

6.4 Alarm Setting

When the measurement values exceeds the set upper or lower limit, the instrument detects it to display the notice on the screen or to output the signal from the external output terminal.

If the measurement values exceeds the alarm range, the color of the pertinent channel "CH" is changes on the MEAS screen.

Set the upper limit alarm to ON for the upper limit control of measurement value.

Set the lower limit alarm to ON for the lower limit control of measurement value.

Upper limit value

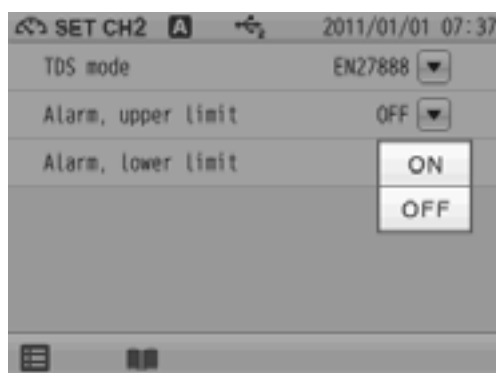



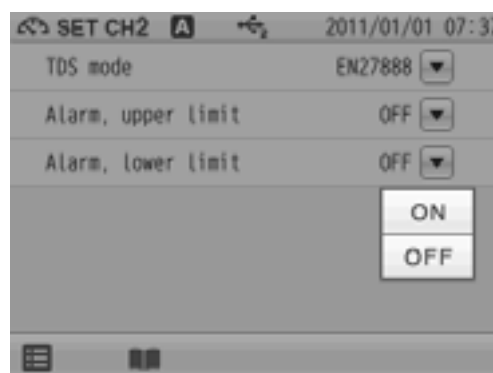

Lower limit value

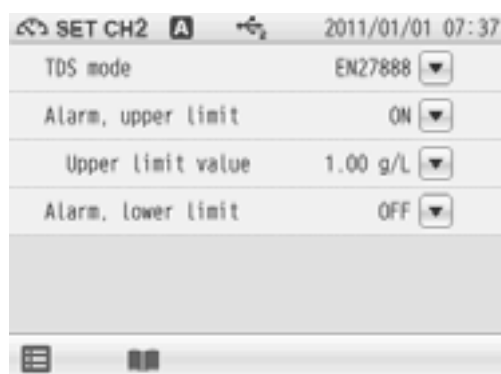

6.4.1 Input Upper or Lower Limit Values



Upper limit value entry



1. When selecting ON the Alarm, upper limit item, the Upper limit value, tap  on the right of the Upper limit value item.
2. Enter an upper limit value on the numerical-key screen.
To change the unit, tap on the unit change key on the right of the numerical-key screen.
3. Tap .
The setting applies.
To cancel the settings, tap .

Lower limit value entry



1. When selecting ON the Alarm, lower limit item, the Lower limit value, tap  on the right of the Lower limit value item.
2. Enter an upper limit value on the numerical-key screen.
To change the unit, tap on the unit change key on the right of the numerical-key screen.
3. Tap .
The setting applies.
To cancel the settings, tap .





6.5 Electrode Model Setting

The electrode model setting in COND measurement applies for TDS measurement (refer to "3.7 Electrode Model Setting" (P.41)).

6.6 TDS Measurement

This section describes the procedures of TDS measurement.



1. Press the MEAS key, and tap the channel setting and the measurement item in the MEAS screen to set "CH2" and "TDS".
2. Tap  to start the measurement.
The measurement value is displayed, and the HOLD indicator blinks until the reading stabilizes.
To stop calibration tap  while the HOLD indicator blinks.
When the reading stabilizes, the value is held and HOLD indicator lights up.
During instantaneous value measurement, or when a measurement value is held, you can store the measurement values by tapping  on the bottom of the screen.
3. After the measurement is completed, tap  to proceed to the next measurement.

Chapter 7 Application Mode

The application mode enables the measurement for the pharmaceutical water inspection methods under various Pharmacopeias by conductivity measurement in conformance to specific measurement methods. By simply submerging the electrode to a sample, the instrument will walk you through the process and will determine the result. This chapter explains about the settings and procedures of measurement using the pharmaceutical water inspection methods under various Pharmacopeias by conductivity measurement.

7.1 Pharmacopeia Mode

In this mode, evaluation of pharmaceutical water (purified water and injection syringe water) in conformity with US Pharmacopeia (USP), European Pharmacopeia (EP), Japanese Pharmacopeia (JP), and Pharmacopoeia of the People's Republic of China (PPRC) can be evaluated. This mode enables evaluation of pharmaceutical water that is measured based on the standards in accordance with the Pharmacopeia regulations in each country.

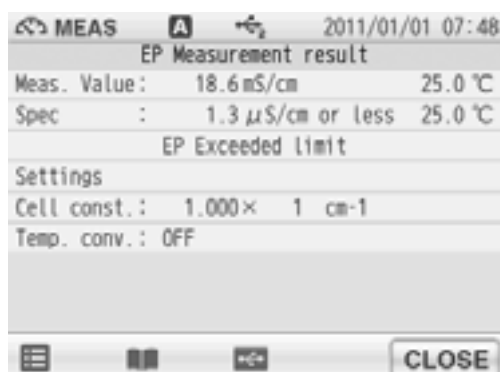

This mode has the function to indicate "Exceeded Limit" which shows that the sample does not conform to the specifications when a measurement value does not satisfy the Pharmacopeia regulations during measurement. When a measurement value is out of the specification after the measurement, the non-conformity is indicated in the measurement results. This applies for printouts.

This mode, you can save the measurement results only into a USB memory and print out them. If you need to save or print out the data, turn ON the "Simultaneously Memory" of "2.6 USB Memory Setting" (P.19) or "Auto Printout" of "2.7 Printer Setting" (P.21) in advance.



7.1.1 Shift to Pharmacopeia Mode





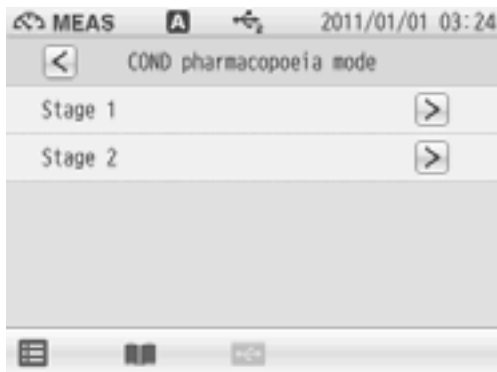

1. Tap  and tap "Application".
2. Tap  on the right of the COND pharmacopeia mode item and select a desired Pharmacopoeia from USP, EP, JP, and CP (PPRC).

7.1.2 Measured by USP (Stage 1)



Evaluation is conducted based on the "7.1.10 Temperature and Conductivity Requirements" (P.63).

If the measured temperature is between the indicated temperatures, the value at temperature lower than the measured temperature is applied as the permissible conductivity.

1. Select the USP in the COND pharmacopeia mode screen.
2. Tap  on the right of the Stage 1 item.
3. Before measurement, set the temperature conversion to OFF in accordance with the regulation prescribed by USP, and the setting of the unit is automatically changed to S/cm. The changed settings are applied.
4. Tap  to proceed to next the procedure.
5. Immerse the COND electrode in sample solution and tap  to start the measurement. When measurement is completed, the conductivity of the sample solution and the measurement condition are displayed as a measurement result.
Tap  to return to the COND pharmacopeia mode screen.

7.1.3 Measured by USP (Stage 2)

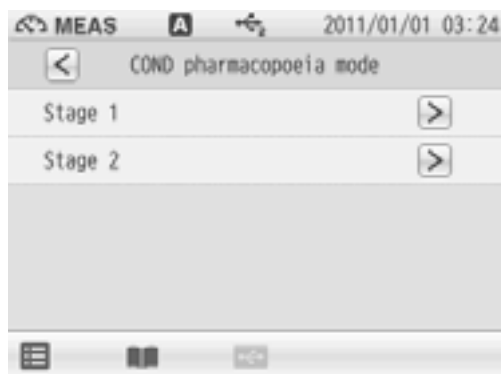

In this mode the value when the measured temperature is at $25^{\circ}\text{C} \pm 1^{\circ}\text{C}$ and the conductivity change for 5 minutes is $0.1 \mu\text{S}/\text{cm}$ or less is to measured whether the target is at the evaluation standard, $2.1 \mu\text{S}/\text{cm}$ or less.

1. Select the USP in the COND pharmacopeia mode screen.
2. Tap **>** on the right of the Stage 2 item.
3. Before measurement, set the temperature conversion to OFF in accordance with the regulation prescribed by USP, and the setting of the unit is automatically changed to S/cm. The changed settings are applied.
4. Tap **OK** to proceed to the next procedure.
5. Immerse the COND electrode in sample solution and tap **START** to start the measurement. When measurement is completed, the conductivity of the sample solution and the measurement condition are displayed as a measurement result.
Tap **CLOSE** to return to the COND pharmacopeia mode screen.

7.1.4 Measured by EP

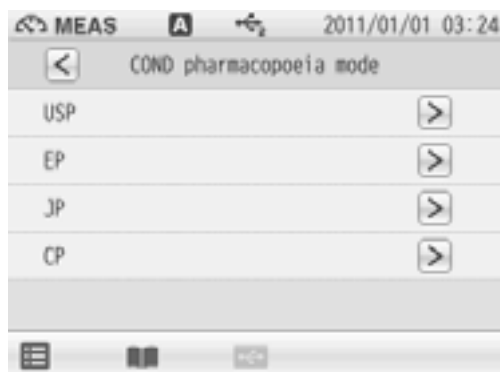

Evaluation is conducted based on the "7.1.10 Temperature and Conductivity Requirements" (P.63).

If the measured temperature is between the indicated temperatures, the value at temperature lower than the measured temperature is applied as the permissible conductivity.

1. Select the EP in the COND pharmacopoeia mode screen.
2. Before measurement, set the temperature conversion to OFF in accordance with the regulation prescribed by EP, and the setting of the unit is automatically changed to S/cm. The changed settings are applied.
3. Tap **OK** to proceed to the next procedure.
4. Immerse the COND electrode in sample solution and tap **START** to start the measurement. When measurement is completed, the conductivity of the sample solution and the measurement condition are displayed as a measurement result.
Tap **CLOSE** to return to the COND pharmacopoeia mode screen.

7.1.5 Measured by JP (OFF-LINE)

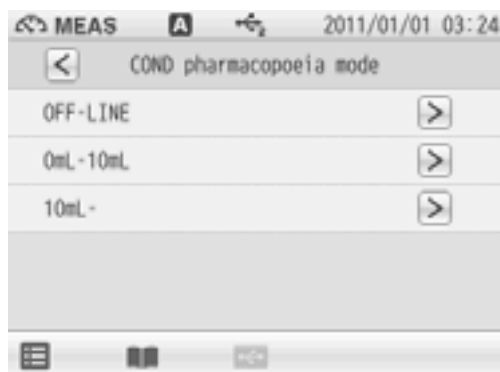

In this mode the value when the measured temperature is at $25^{\circ}\text{C} \pm 1^{\circ}\text{C}$ and the conductivity change for 5 minutes is $0.1 \mu\text{S}/\text{cm}$ or less is the measured whether the target is at the evaluation standard, $2.1 \mu\text{S}/\text{cm}$ or less.

1. Select the JP in the COND pharmacopoeia mode screen.
2. Tap **>** on the right of the OFF-LINE item.
3. Before measurement, set the temperature conversion to OFF in accordance with the regulation prescribed by JP, and the setting of the unit is automatically changed to S/cm. The changed settings are applied.
4. Tap **OK** to proceed to the next procedure.
5. Immerse the COND electrode in sample solution and tap **START** to start the measurement. When measurement is completed, the conductivity of the sample solution and the measurement condition are displayed as a measurement result.
Tap **CLOSE** to return to the COND pharmacopoeia mode screen.

7.1.6 Measured by JP (0mL-10mL (in container))



This is the test procedure for purified water, sterile purified water or water for injection contained in a container of 10 mL or less. The value when the measured temperature is at $25^{\circ}\text{C} \pm 1^{\circ}\text{C}$ and the conductivity change for 5 minutes is $0.1 \mu\text{S}/\text{cm}$ or less is measured whether the target is at the evaluation standard, $2.1 \mu\text{S}/\text{cm}$ or less.

1. Select the JP in the COND pharmacopeia mode screen.
2. Tap on the right of the 0mL-10mL item. The changed settings are applied.
3. Tap to proceed to the next procedure.
4. Immerse the COND electrode in sample solution and tap to start the measurement. When measurement is completed, the conductivity of the sample solution and the measurement condition are displayed as a measurement result.

Tap to return to the COND pharmacopeia mode screen.

7.1.7 Measured by JP (10mL- (in container))

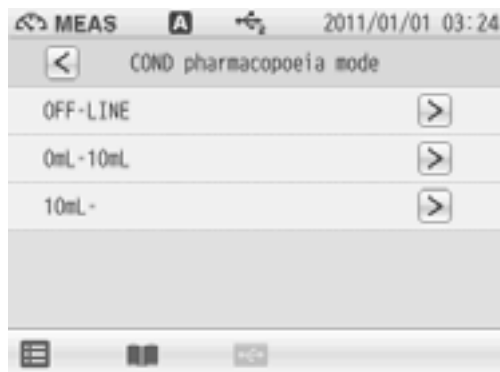

This is the test procedure for purified water, sterile purified water or water for injection contained in a container of 10 mL or more. The value when the measured temperature is at $25^{\circ}\text{C} \pm 1^{\circ}\text{C}$ and the conductivity change for 5 minutes is $0.1 \mu\text{S}/\text{cm}$ or less is measured whether the target is at the evaluation standard, $2.1 \mu\text{S}/\text{cm}$ or less.



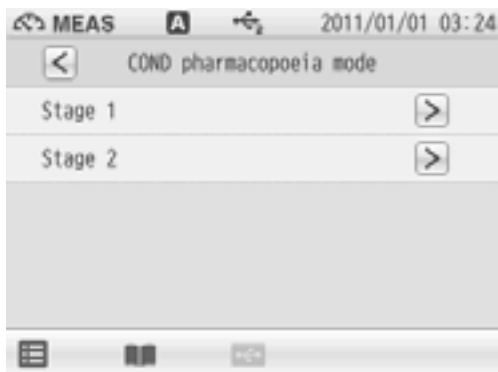

1. Select the JP in the COND pharmacopoeia mode screen.
2. Tap on the right of the 10mL- item.
The changed settings are applied.
3. Tap to proceed to the next procedure.
4. Immerse the COND electrode in sample solution and tap to start the measurement.
When measurement is completed, the conductivity of the sample solution and the measurement condition are displayed as a measurement result.
Tap to return to the COND pharmacopoeia mode screen.

7.1.8 Measured by PPRC (CP) (Stage 1)



Evaluation is conducted based on the "7.1.10 Temperature and Conductivity Requirements" (P.63).

If the measured temperature is between the indicated temperatures, the value at temperature lower than the measured temperature is applied as the permissible conductivity.

1. Select the CP in the COND pharmacopeia mode screen.
2. Tap  on the right of the Stage 1 item.
3. Before measurement, set the temperature conversion to OFF in accordance with the regulation prescribed by PPRC, and the setting of the unit is automatically changed to S/cm. The changed settings are applied.
4. Tap  to proceed to next procedure.
5. Immerse the COND electrode in sample solution and tap  to start the measurement. When measurement is completed, the conductivity of the sample solution and the measurement condition are displayed as a measurement result.
Tap  to return to the COND pharmacopeia mode screen.

7.1.9 Measured by PPRC (CP) (Stage 2)

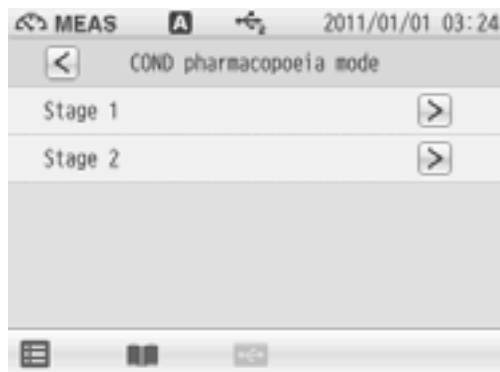

In this mode the value when the measured temperature is at $25^{\circ}\text{C} \pm 1^{\circ}\text{C}$ and the conductivity change for 5 minutes is $0.1 \mu\text{S}/\text{cm}$ or less is measured whether the target is at the evaluation standard, $2.1 \mu\text{S}/\text{cm}$ or less.

1. Select the CP in the COND pharmacopoeia mode screen.
2. Tap **>** on the right of the Stage 2 item.
3. Before measurement, set the temperature conversion to OFF in accordance with the regulation prescribed by PPRC, and the setting of the unit is automatically changed to S/cm. The changed settings are applied.
4. Tap **OK** to proceed to the next procedure.
5. Immerse the COND electrode in sample solution and tap **START** to start the measurement. When measurement is completed, the conductivity of the sample solution and the measurement condition are displayed as a measurement result.
Tap **CLOSE** to return to the COND pharmacopoeia mode screen.

7.1.10 Temperature and Conductivity Requirements

(for non-temperature compensated conductivity measurement)

Temperature (°C)	Required maximum ($\mu\text{S}/\text{cm}$)
0	0.6
5	0.8
10	0.9
15	1.0
20	1.1
25	1.3
30	1.4
35	1.5
40	1.7
45	1.8
50	1.9
55	2.1
60	2.2
65	2.4
70	2.5
75	2.7
80	2.7
85	2.7
90	2.7
95	2.9
100	3.1

Corresponding to USP (Stage1), EP, PPRC (CP) (Stage 1).

Chapter 8 Periodic Inspection Mode

This chapter explains about the function to periodically check performance of the instrument and the electrode in COND measurements using.

We recommend that you perform the check once every 3 months. Setting conditions are described individually in each COND measurement item.

8.1 COND Periodic Inspection Mode Setting

There are two modes for the COND periodical check: Pharmacopoeia mode, or Checker (X-52) mode.

Pharmacopoeia mode

This mode according to the Japanese Pharmacopoeia 16th edition.

You can check the cell constant and assess the conformity of the instrument.

Checker (X52) mode

Only the instrument check can be performed using the optional COND checker (X-52).

NOTE

The Pharmacopoeia mode is based on the corresponding regulations, but not fully compliant with the regulations. Note that the modes may not follow the regulations if the regulations are revised or amended.

8.1.1 Pharmacopoeia Mode

You can perform the inspection compliant with the 16th edition of the Japanese Pharmacopoeia; checking the cell constant (within 5% difference between the actual cell constant and the value written on the COND electrode), measuring standard solutions 3 to 5 times to check the error (within 5%) from the standard values and relative standard deviation (within 2%).

Before the operation, set the cell constant written on the COND electrode referring to "3.1.1 Cell Constant Setting" (P.34).

In this mode, the settings are changed as follows automatically.

Unit: S/cm

Temperature conversion: OFF

Temperature setting: MTC, 20.0°C

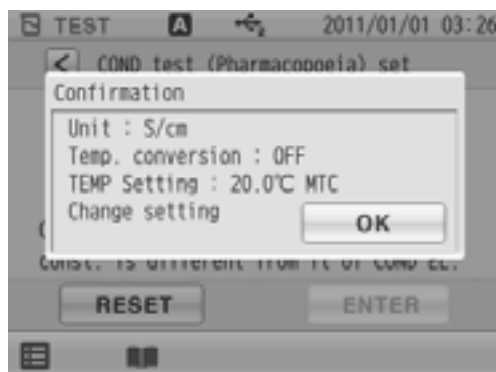

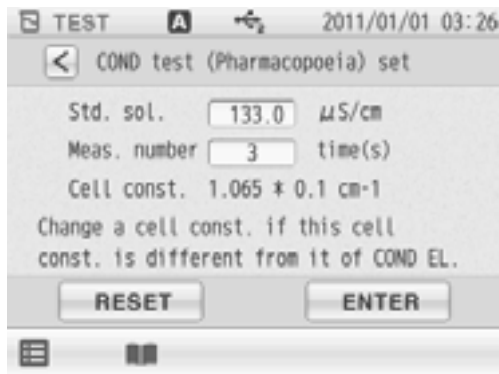

1. Select COND periodic inspection in the check mode screen.
2. Tap **>** on the right of the COND periodic inspection.
3. Tap the Std. sol. value to display the numerical-key screen, and enter value of the standard solution used for the inspection.
4. Tap the Meas. number value, and use **▲** and **▼** to select measurement times (3 to 5 times) for checking relative standard deviation.
5. After the setting is completed, tap **ENTER**.
To return the set value to default, tap **RESET**.

According to the operation guide, perform the check.

When the measurement and check is completed, the result data is displayed.

Result data output

- Measurement values
- Cell constant (calculated from the measred standard solution values)
- Error (difference between the cell constant written on the electrode and the calculated cell constant (regulated value: within 5%))
- Repeated measurement average
- Error (difference between the setting standard solution value and the repeated measurement average (regulated value: within 5%))
- Relative standard deviation (relative standard deviation at the repeated measurement (regulated value: within 2%))

NOTE

An accurate thermometer is required for the measurement. Prepare an accurate thermometer and perform the measurement at 20°C ±0.1°C.

The cell constant calculated in this check does not apply for cell constant calibration.

8.1.2 COND Checker (X-52) Mode

In this mode, the instrument operations are checked by using the optional checker X-52. Refer also to the instruction manual of the checker X-52 before the operation.

When the COND periodical check mode (X-52) starts, the following items are set automatically as follows.

- Unit: S/m
- Cell constant: $1.000 \times 100 \text{ m}^{-1}$
- Temperature setting: ATC

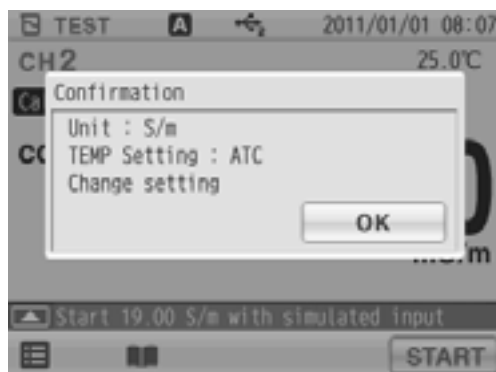

Follow the guidance to check.

Span check

- 19.00 S/m
- 1.900 S/m
- 190.0 mS/m
- 19.00 mS/m
- 1.900 mS/m

Linearity check

- 10.00 S/m
- 1.000 S/m
- 100.0 mS/m
- 10.00 mS/m
- 1.000 mS/m
- 0.000 mS/m

Temperature check

- 0.0°C
- 30.0°C
- 60.0°C
- 100.0°C

NOTE

The conductivity measurement values displayed during in the above operations are not concerned with measurement.
When all the check is completed, the result is displayed automatically.

Span check result

Criteria: $\pm 0.5\%$ ± 1 digit of the full scale

$\pm 1.5\%$ ± 1 digit of the full scale only when 19.00 S/m is entered.

Linearity check result

Criteria: $\pm 0.5\%$ ± 1 digit of the full scale

$\pm 1.5\%$ ± 1 digit of the full scale only when 10.00 S/m is entered.

Temperature check result

Indication error for each entry (regulated value $\pm 0.4^{\circ}\text{C}$).

8.2 Comment Input

A comment can be entered up to 100 characters. Use this function to record periodical checks, etc.

Tap **INPUT** to use the function.

To delete the content input previously, tap **ALL DEL**.



Chapter 9 Data

The DATA screen allows you to check and delete saved measurement data, check the calibration data, save data into a USB memory, and delete all measurement and calibration data.

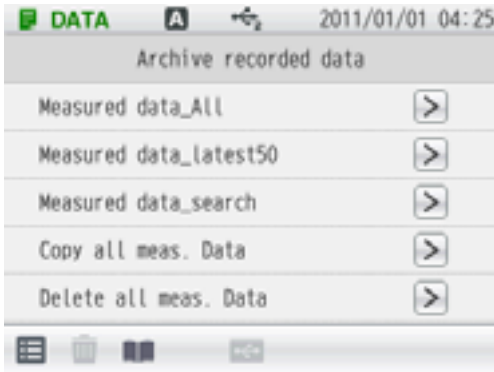

You can search saved data by measurement item, operator, or sample name.

1. Press the DATA key to display the DATA screen.

9.1 Measurement data_All

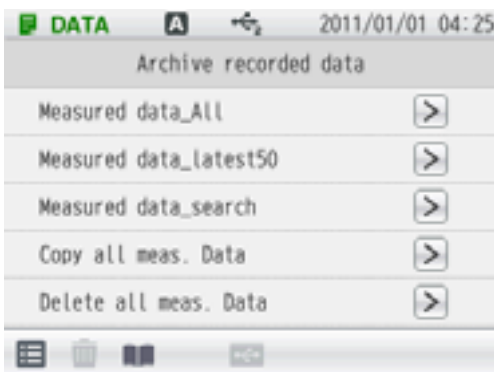

1. Tap on the right of the Measured data_All item.
One item of measured data is displayed in one line. Data can be checked by dragging the item in order. 100 items of data can be viewed on 1 page.
2. Tap to check other pages.
The next 100 items are displayed.
3. Tap of the each data to check details of the data.
4. Flick on a detailed data screen, and the previous/next detailed data screen is displayed.

9.2 Deleting Saved Data



Data can be deleted selectively.

1. Tap on a detailed data screen.
"DELETE" is displayed under the ID number.
2. Tap to return the Measured data_All screen.
"del" is indicated as the ID of the data to be deleted.
3. After that, tap to execute deletion.
To execute, tap . Not to execute, tap .







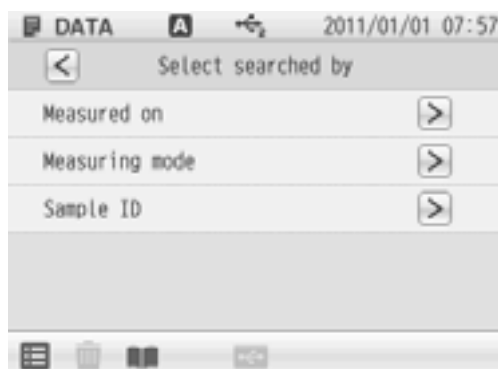

9.3 Measurement data_latest50

You can check just the latest 50 data.
The data are sorted in descending order of measurement data.

9.4 Measured data_Search



You can search saved data by one of measurement item, operator, or sample name. (You can not use mutiple seach conditions at a time.)

1. Tap  on the right of the Measured data_search item.
2. Search by measurement date
Enter measurement date in the measurement date search screen, and tap  .
Search by measurement item
Tap  on the right of each measured items.
Search by operator name
Enter operator name in input screen, and tap  .
Search by sample ID
Enter sample name in input screen, and tap  .
3. When you select Measured on, enter the measurement date and tap  on the next screen.
When you select Measuring mode, tap  on a measurement item on the next screen.
When you select User name, enter operator name and tap  on the next screen.
When you select Sample ID, enter sample name and tap  item on the next screen.
Search is performed and the result is displayed.

9.5 Copy all Meas. Data

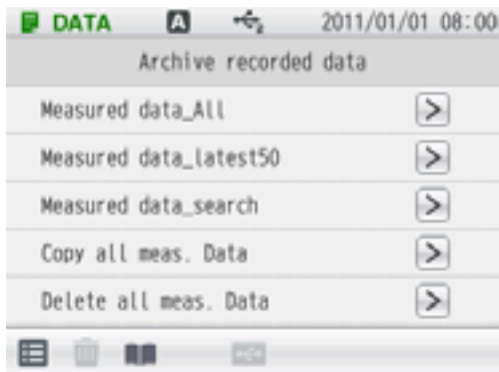

You can save the copy of the measurement data saved in the instrument into a USB memory. To execute the copy, connect a USB memory to the instrument.

1. Tap  on the right of the Copy all meas. Data.
2. Tap **YES** to copy the all measurement data. To cancel the operation, tap **NO**.
3. Tap **OK** in the Copy all meas. Data completion screen.

NOTE

Before copying data, make sure that sufficient capacity is available in the USB memory. If the copy stops in the middle, turn OFF the power and reboot the instrument, and then execute the copy again.

9.6 Delete all meas. Data

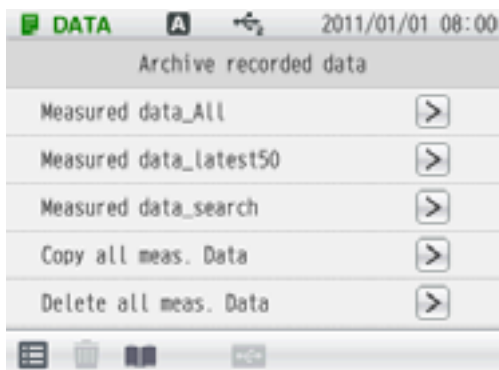

You can delete all measurement data saved in the instrument.

1. Tap  on the right of the Delete all meas. Data
2. Tap **YES** to delete the all measurement data. To cancel the operation, tap **NO**.
3. Tap **OK** in the Delete all meas. DATA screen.

Chapter 10 Specifications

10.1 Specifications

Measuring object	Item	Description
Temperature	Measuring principle	Thermistor method
	Display range	-30.0°C to 130.0°C
	Measuring range	0.0°C to 100.0°C
	Resolution	0.1°C
	Repeatability	±0.1°C ±1 digit
Conductivity (COND)	Measuring principle	2 AC bipolar method
	Measuring range	Cell constant 100 m ⁻¹ : 0.000 mS/m to 19.99 S/m
		Cell constant 10 m ⁻¹ : 0.0 μS/m to 1.999 S/m
		Cell constant 1000 m ⁻¹ : 0.00 mS/m to 199.9 S/m
	Resolution	0.05% of full scale
Repeatability	±0.5% ±1 digit of full scale	
Resistivity (Resist)	Measuring principle	Conversion from conductivity value
	Measuring range	Cell constant 100 m ⁻¹ : 0.00 Ω•m to 199.9 kΩ•m
		Cell constant 10 m ⁻¹ : 0.0 Ω•m to 1.999 MΩ•m
		Cell constant 1000 m ⁻¹ : 0.000 Ω•m to 19.99 kΩ•m
	Resolution	0.05% of full scale
Repeatability	±0.5% ±1 digit of full scale	
Salinity (SAL)	Measuring principle	Conversion from conductivity value
	Measuring range	0.00 PPT to 80.00 PPT (0.000% to 8.000%)
	Resolution	0.01 PPT (0.001%)
TDS	Measuring principle	Conversion from conductivity value
	Measuring range	0.01 mg/L to 1000 g/L
	Resolution	0.01 mg/L

10.2 Default Settings

10.2.1 Meter Default Settings

Item		Selection item/Setting range	Default values
Security	Security management function	Enable/Disable	Disable
Hold condition	Hold setting mode	EXACT/NORMAL/BRIEF/TIME/CUSTOM/OFF (Manual)	NORMAL
In selecting "TIME"	Time setting value	2 seconds to 999 seconds	10 seconds
In selecting "CUSTOM"	Time setting value	2 seconds to 60 seconds	10 seconds
	Conductivity variation width	1 to 100 digit	1 digit
	Salinity variation width	0.10 PPT to 10.00 PPT	0.30 PPT
	Resistivity variation width	1 to 100 digit	1 digit
	TDS variation width	0.1 mg/L to 100.0 mg/L	100.0 mg/L
Interval memory	Interval memory function	Enable/Disable	Disable
	Time setting value	1 second to 999 seconds	30 seconds

10.2.2 Measurement Condition Default Settings (Can be set per operator)

Item		Selection item/ Setting range	Default values	
Conductivity measurement condition	Alarm condition	Upper limit value setting	Enable/Disable	Disable
		Lower limit value setting	Enable/Disable	Disable
		Upper limit value	0.3 μ S/m to 199.9 S/m	199.9 S/m
		Lower limit value	0.3 μ S/m to 199.9 S/m	0.3 μ S/m
	Measurement value unit		S/m, S/cm, FIX	S/m
	Temperature setting	Temperature setting	ATC (Automatic temperature compensation)/ MTC (Manual temperature compensation)	ATC
		Temperature input value in selecting "MTC"	0.0°C to 100.0°C	25.0°C
	Temperature conversion	Temperature conversion function	Pure water, Natural water, Manual, Disable	Manual
		Temperature conversion coefficient	0.00%/°C to 10.00%/°C	2.00%/°C
	Electrode data	Model		None
		lot No.		None
Salinity measurement condition	Alarm condition	Upper limit value setting	Enable/Disable	Disable
		Lower limit value setting	Enable/Disable	Disable
		Upper limit value	0.00 PPT to 80.00 PPT (0.000% to 8.000%)	80.00 PPT
		Lower limit value	0.00 PPT to 80.00 PPT (0.000% to 8.000%)	0.00 PPT
	Measurement value unit		PPT, %	PPT
Resistivity measurement condition	Alarm condition	Upper limit value setting	Enable/Disable	Disable
		Lower limit value setting	Enable/Disable	Disable
		Upper limit value	0.0 Ω •m to 199.9 M Ω •m	199.9 Ω •m
		Lower limit value	0.0 Ω •m to 199.9 M Ω •m	0.0 Ω •m

Chapter 10 Specifications

Item		Selection item/ Setting range	Default values	
TDS measurement condition	Alarm condition	Upper limit value setting	Enable/Disable	Disable
		Lower limit value setting	Enable/Disable	Disable
		Upper limit value	0.00 mg/L to 1000.0 g/L	1.00 g/L
		Lower limit value	0.00 mg/L to 1000.0 g/L	0.00 mg/L
	TDS measurement mode		EN27888/FACTOR	EN27888
	TDS FACTOR value		0.4 to 1.0	0.5
Sample ID			None	
Interface condition	Language		Japanese/English/ Chinese/Korean	English
	Screen setting	Screen theme	STANDARD, COOL, MONOTONE, KYOTO	STANDARD
		Brightness	1 to 10	5
		Power saving mode	Enable/Disable	Disable
		Back light off time	1 to 999 minutes	60 minutes
	Sound setting	Volume	0 to 9	5
		Sound theme	STANDARD1, STANDARD2, AQUA, KYOTO	STANDARD1
	Printer setting	Automatic printing	Enable/Disable	Disable
		Printing format	BRIEF/NORMAL/GLP/ CUSTOMIZE	NORMAL
	USB memory	Simultaneous memory	Enable/Disable	Disable

10.3 Options

This section lists spare and optional parts for the pH meter. These parts are possible through HORIBA distributors. Place an order specifying their name, model, and part number.

Part name		Part number	Remarks
AC adapter	AC adapter, Cable (UL, 120 V)	3014031951	
	AC adapter, Cable (EU, 230 V)	3014031952	
Plain paper printer	Printer (USA, 120 V)	3014030146	Printer cable sold separately
	Printer (EU, 230 V)	3014030147	
	Printer cable	3014030148	1.5 m
	Roll paper	3014030149	20 rolls/set
	Ink ribbon	3014030150	5 pcs/set
USB cable		3200373941	1 m
Serial cable		3014030151	
Analog (alarm) output cable		3014030152	
Electrode stand (Standard type)		3200382557	
Electrode stand (Long type)		3200382560	
Stand arm		3200373991	
Sensor holder		3200373961	
X-51 Digital Simulator		—	For pH, mV, ION, and DO
X-52 Digital Simulator		—	For COND

For any question regarding this product,
please contact your local agency,
or inquire from the Customer Registration website
(<http://www.horiba.com/register>)

HORIBA Ltd.

1st edition: October 2011
CODE: GZ0000260900

